

Indirect Diesel Space Heater

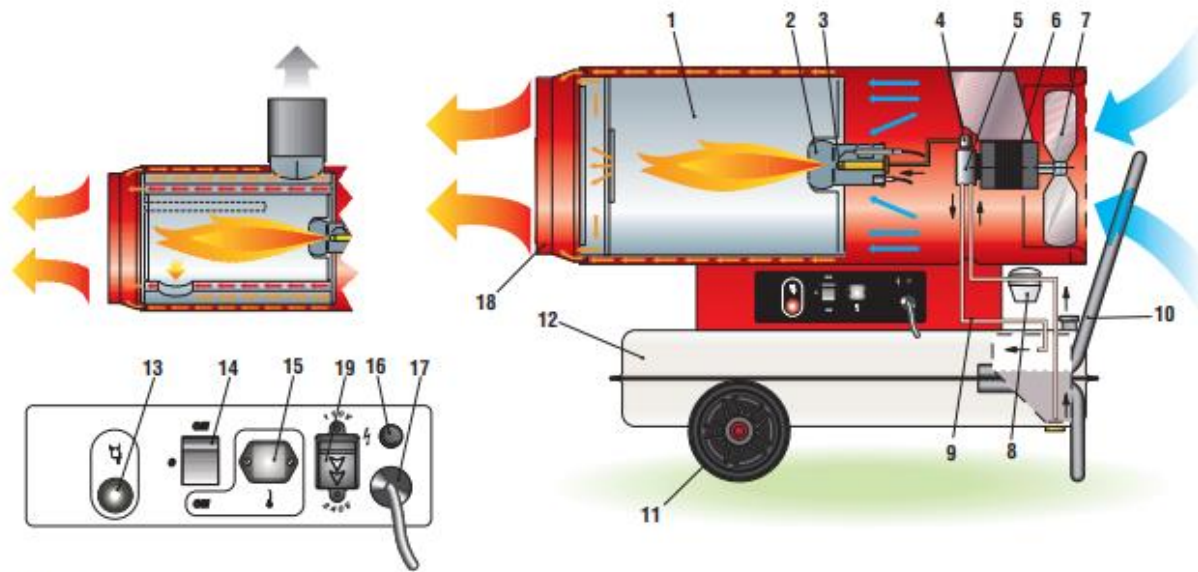

Operator's Manual



- | | |
|----------------------|-----------------------------------|
| 1 COMBUSTION CHAMBER | 11 WHEEL |
| 2 BURNER | 12 FUEL TANK |
| 3 NOZZLE | 13 RESET BUTTON WITH CONTROL LAMP |
| 4 SOLENOID VALVE | 14 MAIN SWITCH |
| 5 DIESEL PUMP | 15 ROOM THERMOSTAT PLUG |
| 6 MOTOR | 16 CONTROL LAMP |
| 7 VENTILATOR FAN | 17 POWER CORD |
| 8 FUEL FILTER | 18 OUTLET CONE |
| 9 FUEL CIRCUIT | 19 INPUT VOLTAGE SWITCH |
| 10 SUPPORT/HANDLE | |

This heater must only be used in accordance with the instructions herein. Only a reliable continuous power supply should be used. If the heater is switched off or unplugged without going through the cooling down procedure the ducting is likely to be burned and damaged requiring replacement and or repair to the heater. Burnt ducting and or burnt paintwork results from operator error, and or unreliable power supply and is not covered by Accidental Damage Waiver (ADW) or any hire revenue received. Damage due to negligence or operator error is charged post event from the Deferred Deposit advised on your Proforma Invoice. Please refer to the section "Stopping the heater" below for the procedure in finishing with the heater or switched off. The heater MUST go through a cooling cycle which can only occur if the Stopping the Heater is followed.

IMPORTANT

Before using the heater, read and understand all instructions and follow them carefully. The manufacturer is not responsible for damages to goods or persons due to improper use of units.

GENERAL RECOMMENDATIONS

The hot air generators run on diesel fuel. Those with direct combustion send hot air and the combustion products into the room, while those with indirect combustion are fitted with a flue to take the fumes away through the chimney.

Always follow local ordinances and codes when using this heater:

- Read and follow this owner's manual before using the heater;
- Use only in places free of flammable vapours or high dust content;
- Never use heater in immediate proximity of flammable materials (the minimum distance must be 2 m);
- Make sure fire fighting equipment is readily available;
- Make sure sufficient fresh outside air is provided according to the heater requirements. Direct combustion heaters should only be used in well vented areas in order to avoid carbon monoxide poisoning;
- the generator is installed near a chimney to take away the fumes (see the paragraph "FUMES FLUE POSITIONING DIAGRAM") and connected to an electrical switchboard;
- Never block air inlet (rear) or air outlet (front);
- In case of very low temperatures add kerosene to the heating oil;
- Make sure heater is always under surveillance and keep children and animals away from it;
- Before starting the heater always check free rotation of ventilator;
- Unplug heater when not in use.

OPERATION

Before any attempt of starting the heater is made, check that your electrical supply conforms to the data on the model plate.

Warning



For models "DV," check that the arrows on the voltage supply selector key cover (Fig. 1) are pointing to the voltage value required.

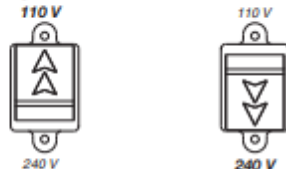

Fig. 1

If necessary:

- remove the cover;
- press deflector (18) to the position required;
- replace the protective cover.

Attenzione



To operate the machine, must install the air dispersion cone (18) on the front of the machine as shown in the figure above ("Operating diagram").

Warning



Mains must be fitted with a thermo-magnetic differential switch. Unit plug must be linked to a socket with a mains switch.

You can run the generator in manual by setting switch (14) to ON.

The generator can only work automatically when a control device, such as for example a thermostat or a timer, is connected to the generator. Connection to the generator is made by removing the socket cover (15) and inserting the thermostat plug.

To start the machine you must:

- if connected to the thermostat, turn the switch to (ON + );
- if not connected to the thermostat, turn the switch to (ON);

When unit is started for the first time or is started after the oil tank has been totally emptied, the flow of oil to the burner may be impaired by air in the circuit. In this case the control box will cut out the heater and it might be necessary to renew the starting procedure once or twice by depressing the reset button (13).

Should the heater not start, check that oil tank is full and depress reset button (13).

Should the heater still not work, please refer to chapter "OBSERVED FAULTS, CAUSES AND REMEDIES".

STOPPING THE HEATER

Set main switch (14) on "0" position or turn thermostat or other control device on lowest setting.

The flame goes out and the fan continues to work for approx. 90 sec. cooling the combustion chamber.

SAFETY DEVICES

The unit is fitted with an electronic flame control box. In case of malfunction this box will cut in and stop the heater, at the same time the pilot lamp in the control box reset button (13) will light up.

Heaters are also equipped with an overheat thermostat safety cut out which will stop the heater in case of overheating. This thermostat will reset automatically but you will have to depress button (13) on control box before being able to restart the heater.

TRANSPORT

Warning



Before making any attempt to restart heater find and eliminate reason of overheating.

Before heater is moved it must be stopped and unplugged. Before moving the heater wait till it has totally cooled off and make sure oil tank cap is securely fixed.

The hot air generators with wheels must be wheeled. The suspended version which has no wheels must be transported with adequate machinery.

MAINTENANCE

Preventive and regular maintenance will ensure a long trouble free life to your heater.

Warning



Never service heater while it is plugged in, operating or hot. Severe burns or electrical shock can occur.

Every 50 hours of operation: disassemble filter and wash with clean oil, remove upper body parts and clean inside and ventilator with compressed air, check correct attachment of H.T. connectors to the electrodes and check H.T. cables, remove burner assembly, clean and check electrode settings, adjust according to scheme "REGULATION OF ELECTRODES".

OBSERVED FAULTS, CAUSES AND REMEDIES

OBSERVED FAULT	CAUSE	REMEDY
Motor does not start, no ignition	No electrical current	<ul style="list-style-type: none"> ● Check mains. ● Check proper positioning and function of switch. ● Check fuse
	Wrong setting of room thermostat or other control	Check correct setting of heater control. If thermostat, make sure selected temperature is higher than room temperature
	Thermostat or other control defective	Replace control device
	Electrical Motor Defective	Replace electrical motor
	Electrical motor bearings defective	Replace electrical motor bearings
	Burned out condenser	Replace condenser
Motor starts, no ignition or cuts out	Electric ignitor defective	<ul style="list-style-type: none"> ● Check connection of H.T. leads to electrodes and transformer. ● Check electrodes setting (see scheme *REGULATION OF ELECTRODES*) ● Check electrodes for cleanliness. ● Replace H.T. Transformer
	Flame control box defective	Replace Control Box
	Photocell defective	Clean or replace photocell
	Not enough or no fuel at all at burner	<ul style="list-style-type: none"> ● Check state of motor-pump plastic coupling ● Check fuel line system including filter for possible leaks. ● Clean or replace oil nozzle
	Solenoid defective	<ul style="list-style-type: none"> ● Check electrical connection. ● Check thermostat LI. ● Clean or replace solenoid
Motor starts, heater emits smoke	Not enough combustion air	<ul style="list-style-type: none"> ● Make sure air inlet and outlet are free ● Check setting of combustion air flap ● Clean burner disc
	Too much combustion air	Check setting of combustion air flap
	Fuel contaminated or contains water	<ul style="list-style-type: none"> ● Drain fuel in tank with clean fuel ● Clean oil filter
	Air leaks in fuel circuit	Check the seals on the ducts and the diesel filter
	Not enough fuel at burner	<ul style="list-style-type: none"> ● Check pump pressure ● Clean or replace fuel nozzle
	Too much fuel at burner	<ul style="list-style-type: none"> ● Check pump pressure ● Replace nozzle
Heater does not stop	Solenoid defective	Replace solenoid coil or complete solenoid

CHIMNEY LAY-OUT RECOMMENDATION

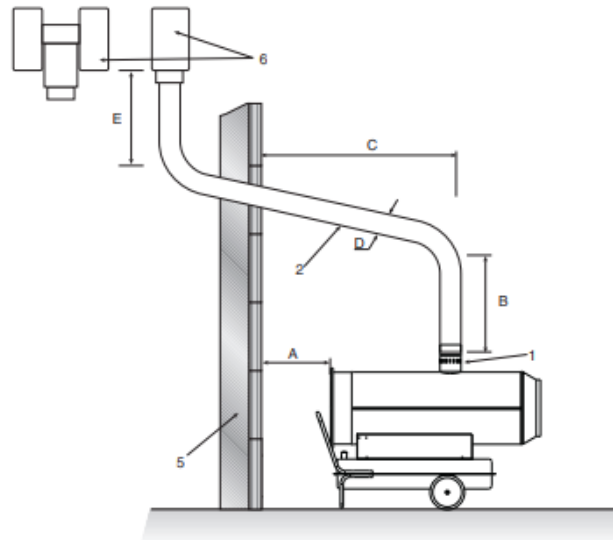
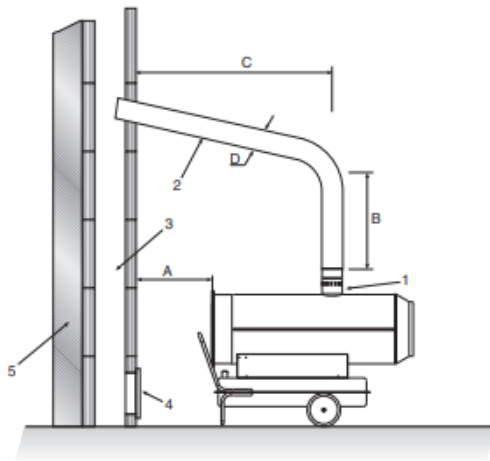

DESCRIPTION ENGLISH

- A) Minimal 1 m
 - B) Minimal 1 m
 - C) The shortest
 - D) The same or bigger than the smokes outlet diameter of heater
 - E) Minimal 1 m
 - 1) Anti-wind device provided with the heater
 - 2) Horizontal crossing with minimal upside angle pitch of 5°
 - 3) Chimney 20 x 20 cm of minimal inside measure
 - 4) Chimney anti-explosion flap door
 - 5) External seating wall
 - 6) Chimney ending H shape
- N.B. Above recommendation indicative only. Have your installation checked by local authority.**