

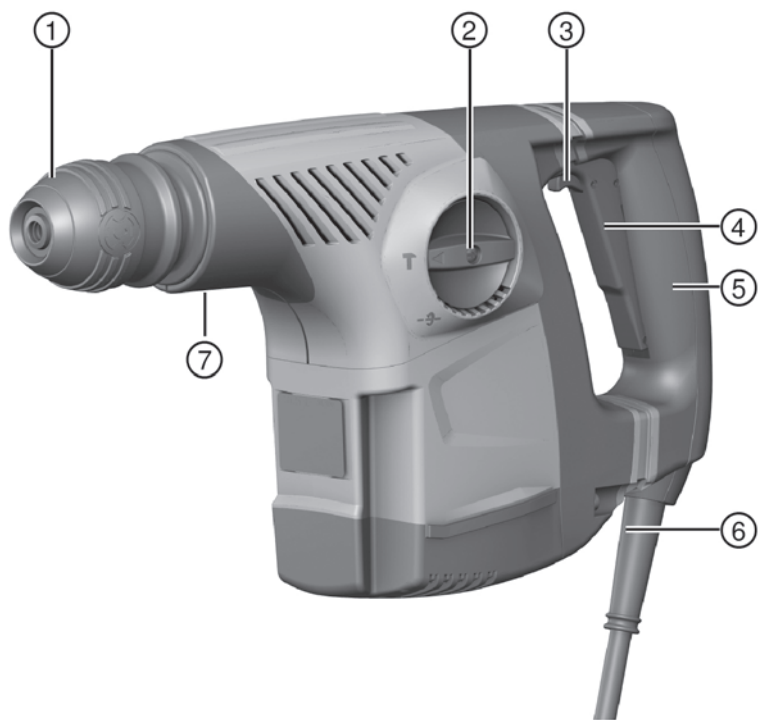

TE 300-AVR

Deutsch	1
English	8
Magyar	16
Polski	23
Русский	32
Česky	40
Slovenčina	48
Hrvatski	55
Slovenščina	63
Български	70
عربي	79
日本語	87
한국어	94
繁體中文	101

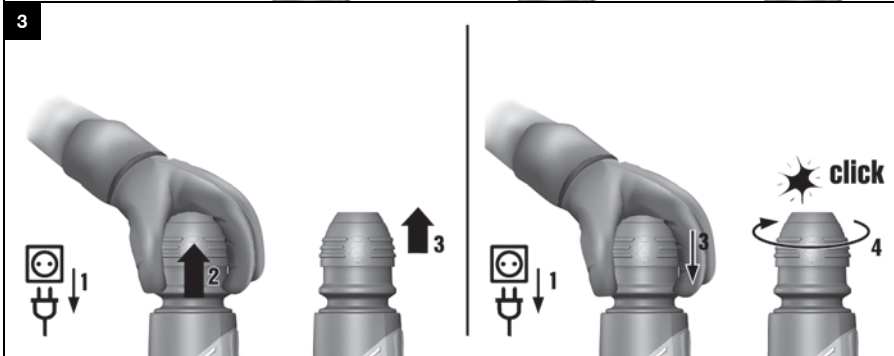

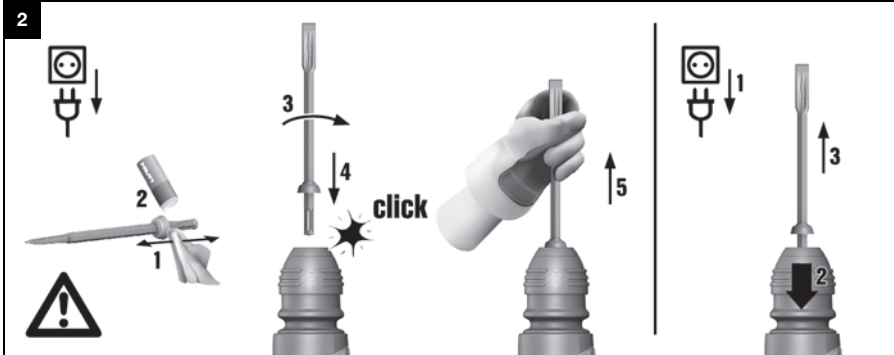

6

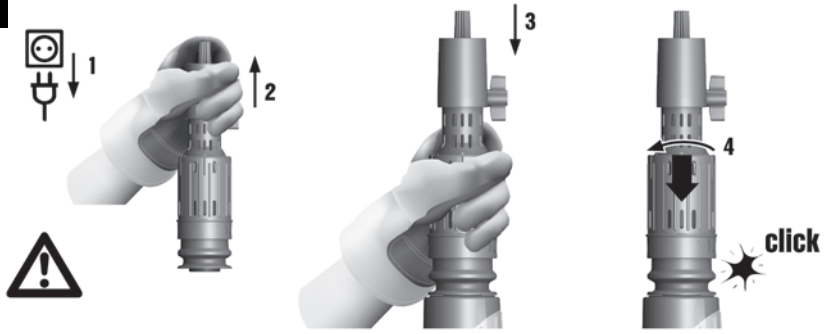

7

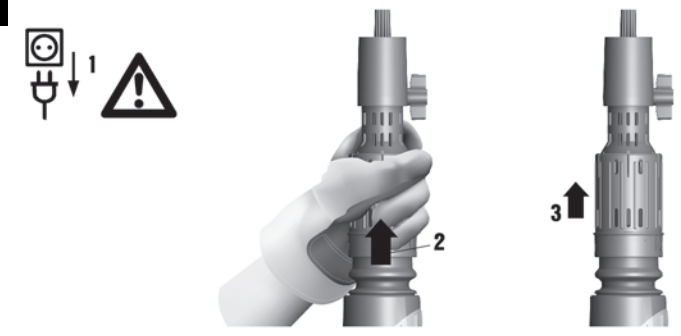

8

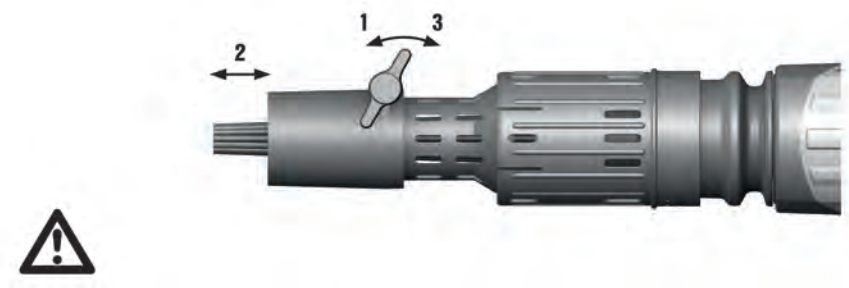

9

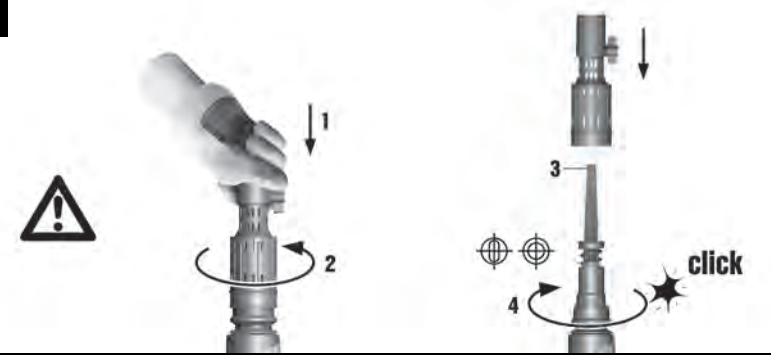

TE 300-AVR

de	Original-Bedienungsanleitung	1
en	Original operating instructions	8
hu	Eredeti használati utasítás	16
pl	Oryginalna instrukcja obsługi	23
ru	Оригинальное руководство по эксплуатации	32
cs	Originální návod k obsluze	40
sk	Originálny návod na obsluhu	48
hr	Originalne upute za uporabu	55
sl	Originalna navodila za uporabo	63
bg	Оригинално Ръководство за експлоатация	70
ar	دليل الاستعمال الأصلي	79
ja	オリジナル取扱説明書	87
ko	오리지널 사용 설명서	94
zh	原始操作說明	101

Original operating instructions

1 Information about the operating instructions

1.1 About these operating instructions

- Read these operating instructions before the product is used or operated for the first time. This is a prerequisite for safe, trouble-free handling and use of the product.
- Observe the safety instructions and warnings in these operating instructions and on the product.
- Always keep the operating instructions with the product and make sure that the product is accompanied by these operating instructions only, when the product is given to other persons.



1.2 Explanation of symbols used

1.2.1 Warnings

Warnings alert persons to hazards that occur when handling or using the product. The following signal words are used:

DANGER

DANGER !

- ▶ Draws attention to imminent danger that will lead to serious personal injury or fatality.

WARNING

WARNING !

- ▶ Draws attention to a potential threat of danger that can lead to serious injury or fatality.





CAUTION

CAUTION !

- ▶ Draws attention to a potentially dangerous situation that could lead to personal injury or damage to the equipment or other property.





1.2.2 Symbols in the operating instructions

The following symbols are used in these operating instructions:

	Comply with the operating instructions
	Instructions for use and other useful information
	Dealing with recyclable materials
	Do not dispose of electric equipment and batteries as household waste

1.2.3 Symbols in illustrations







The following symbols are used in illustrations:

	These numbers refer to the illustrations at the beginning of these operating instructions.
	The numbering reflects the sequence of operations shown in the illustrations and may deviate from the steps described in the text.
	Item reference numbers are used in the overview illustration and refer to the numbers used in the key in the product overview section.
	These characters are intended to specifically draw your attention to certain points when handling the product.

1.3 Product-dependent symbols

1.3.1 Symbols on the product

The following symbols can be used on the product:

	Chiseling
	Chisel positioning
	Protection class II (double-insulated)
	Li-ion battery
	Never use the battery as a striking tool.
	Do not drop the battery. Never use a battery that has suffered an impact or is damaged in any other way.



1.4 Product information

products are designed for professional users and only trained, authorized personnel are permitted to operate, service and maintain the products. This personnel must be specifically informed about the possible hazards. The product and its ancillary equipment can present hazards if used incorrectly by untrained personnel or if used not in accordance with the intended use.

The type designation and serial number are printed on the rating plate.

- ▶ Write down the serial number in the table below. You will be required to state the product details when contacting Hilti Service or your local Hilti organization to inquire about the product.

Product information

Breakers	TE 300-AVR
Generation	01
Serial no.	

1.5 Declaration of conformity

We declare, on our sole responsibility, that the product described here complies with the applicable directives and standards. A copy of the declaration of conformity can be found at the end of this documentation.

The technical documentation is filed and stored here:

Hilti Entwicklungsgesellschaft mbH | Tool Certification | Hiltistrasse 6 | 86916 Kaufering, Germany

2 Safety

2.1 Safety instructions

The safety rules given in the following section contain all general safety rules for electric tools which, in accordance with the applicable standards, require to be listed in the operating instructions. Accordingly, some of the rules listed may not be relevant to this electric tool.

2.1.1 General power tool safety warnings

WARNING Read all safety warnings, instructions, illustrations and specifications provided with this power tool. Failure to follow all instructions listed below may result in electric shock, fire and/or serious injury. **Save all warnings and instructions for future reference.**

The term "power tool" in the warnings refers to your mains-operated (corded) power tool or battery-operated (cordless) power tool.

Work area safety

- ▶ **Keep work area clean and well lit.** Cluttered or dark areas invite accidents.
- ▶ **Do not operate power tools in explosive atmospheres, such as in the presence of flammable liquids, gases or dust.** Power tools create sparks which may ignite the dust or fumes.
- ▶ **Keep children and bystanders away while operating a power tool.** Distractions can cause you to lose control.

Electrical safety

- ▶ **Power tool plugs must match the outlet. Never modify the plug in any way. Do not use any adapter plugs with earthed (grounded) power tools.** Unmodified plugs and matching outlets will reduce risk of electric shock.
- ▶ **Avoid body contact with earthed or grounded surfaces, such as pipes, radiators, ranges and refrigerators.** There is an increased risk of electric shock if your body is earthed or grounded.
- ▶ **Do not expose power tools to rain or wet conditions.** Water entering a power tool will increase the risk of electric shock.
- ▶ **Do not abuse the cord. Never use the cord for carrying, pulling or unplugging the power tool. Keep cord away from heat, oil, sharp edges or moving parts.** Damaged or entangled cords increase the risk of electric shock.
- ▶ **When operating a power tool outdoors, use an extension cord suitable for outdoor use.** Use of a cord suitable for outdoor use reduces the risk of electric shock.
- ▶ **If operating a power tool in a damp location is unavoidable, use a residual current device (RCD) protected supply.** Use of an RCD reduces the risk of electric shock.



Personal safety

- ▶ **Stay alert, watch what you are doing and use common sense when operating a power tool. Do not use a power tool while you are tired or under the influence of drugs, alcohol or medication.** A moment of inattention while operating power tools may result in serious personal injury.
- ▶ **Use personal protective equipment. Always wear eye protection.** Protective equipment such as a dust mask, non-skid safety shoes, hard hat or hearing protection used for appropriate conditions will reduce personal injuries.
- ▶ **Prevent unintentional starting. Ensure the switch is in the off-position before connecting to power source and/or battery pack, picking up or carrying the tool.** Carrying power tools with your finger on the switch or energising power tools that have the switch on invites accidents.
- ▶ **Remove any adjusting key or wrench before turning the power tool on.** A wrench or a key left attached to a rotating part of the power tool may result in personal injury.
- ▶ **Do not overreach. Keep proper footing and balance at all times.** This enables better control of the power tool in unexpected situations.
- ▶ **Dress properly. Do not wear loose clothing or jewellery. Keep your hair and clothing away from moving parts.** Loose clothes, jewellery or long hair can be caught in moving parts.
- ▶ **If devices are provided for the connection of dust extraction and collection facilities, ensure these are connected and properly used.** Use of dust collection can reduce dust-related hazards.
- ▶ **Do not let familiarity gained from frequent use of tools allow you to become complacent and ignore tool safety principles.** A careless action can cause severe injury within a fraction of a second.

Power tool use and care

- ▶ **Do not force the power tool. Use the correct power tool for your application.** The correct power tool will do the job better and safer at the rate for which it was designed.
- ▶ **Do not use the power tool if the switch does not turn it on and off.** Any power tool that cannot be controlled with the switch is dangerous and must be repaired.
- ▶ **Disconnect the plug from the power source and/or remove the battery pack, if detachable, from the power tool before making any adjustments, changing accessories, or storing power tools.** Such preventive safety measures reduce the risk of starting the power tool accidentally.
- ▶ **Store idle power tools out of the reach of children and do not allow persons unfamiliar with the power tool or these instructions to operate the power tool.** Power tools are dangerous in the hands of untrained users.
- ▶ **Maintain power tools and accessories. Check for misalignment or binding of moving parts, breakage of parts and any other condition that may affect the power tool's operation. If damaged, have the power tool repaired before use.** Many accidents are caused by poorly maintained power tools.
- ▶ **Keep cutting tools sharp and clean.** Properly maintained cutting tools with sharp cutting edges are less likely to bind and are easier to control.
- ▶ **Use the power tool, accessories and tool bits etc. in accordance with these instructions, taking into account the working conditions and the work to be performed.** Use of the power tool for operations different from those intended could result in a hazardous situation.
- ▶ **Keep handles and grasping surfaces dry, clean and free from oil and grease.** Slippery handles and grasping surfaces do not allow for safe handling and control of the tool in unexpected situations.

Service

- ▶ **Have your power tool serviced by a qualified repair person using only identical replacement parts.** This will ensure that the safety of the power tool is maintained.

2.1.2 Hammer safety warnings

Safety instructions for all operations

- ▶ **Wear ear protectors.** Exposure to noise can cause hearing loss.
- ▶ **Use auxiliary handle(s), if supplied with the tool.** Loss of control can cause personal injury.
- ▶ **Hold the power tool by insulated gripping surfaces, when performing an operation where the cutting accessory may contact hidden wiring or its own cord.** Cutting accessory contacting a "live" wire may make exposed metal parts of the power tool "live" and could give the operator an electric shock.

2.1.3 Additional safety instructions

Personal safety

- ▶ Use the tool only when it is in technically faultless condition.
- ▶ Never tamper with or modify the tool in any way.



- ▶ Always hold the tool securely by the grips provided. Keep the grips dry, clean and free from oil and grease.
- ▶ Wear protective gloves also when changing the accessory tool. Touching the accessory tool presents a risk of injury (cuts or burns).
- ▶ Take breaks between working and do physical exercises to improve the blood circulation in your fingers. Exposure to vibration during long periods of work can lead to disorders of the blood vessels and nervous system in the fingers, hands and wrists.
- ▶ The tool is not intended for use by debilitated persons who have received no special training.
- ▶ Keep bystanders, children and visitors away while operating a power tool.
- ▶ Before beginning the work, check the hazard classification of the dust that will be produced. Use an industrial vacuum cleaner with an officially approved protection classification in compliance with locally applicable dust protection regulations.
- ▶ Use a dust removal system and suitable vacuum cleaner whenever possible. Dust from materials, such as paint containing lead, some wood species, concrete/masonry/stone containing silica, and minerals as well as metal, may be harmful.
- ▶ Make sure that the workplace is well ventilated and, where necessary, wear a respirator appropriate for the type of dust generated. Contact with or inhalation of the dust may cause allergic reactions and/or respiratory or other diseases to the operator or bystanders. Certain kinds of dust are classified as carcinogenic such as oak and beech dust, especially in conjunction with additives for wood conditioning (chromate, wood preservative). Material containing asbestos may be handled only by specialists.
- ▶ Observe the national health and safety requirements.

Electrical safety

- ▶ Before beginning work, check the working area for concealed electric cables or gas and water pipes. External metal parts of the power tool may give you an electric shock if you damage an electric cable accidentally.
- ▶ Check the power tool's supply cord at regular intervals and have it replaced by a qualified specialist if found to be damaged. If the power tool's supply cord is damaged it must be replaced with a specially-prepared and approved supply cord available from Hilti Customer Service. Check extension cords at regular intervals and replace them if found to be damaged. Do not touch the supply cord or extension cord if it is damaged while working. Disconnect the supply cord plug from the power outlet. Damaged supply cords or extension cords present a risk of electric shock.

Careful handling and use of electric tools

- ▶ Secure the workpiece. A workpiece clamped in a vice or secured by some other clamping device is more secure than when held only by hand.
- ▶ Ensure that the accessory tools used are compatible with the tool-holder system and that they are correctly secured in the tool holder.
- ▶ Switch the electric tool off and unplug the supply cord in the event of an interruption in the electric supply in order to avoid inadvertent restarting when the power returns.

3 Description

3.1 Overview of the product

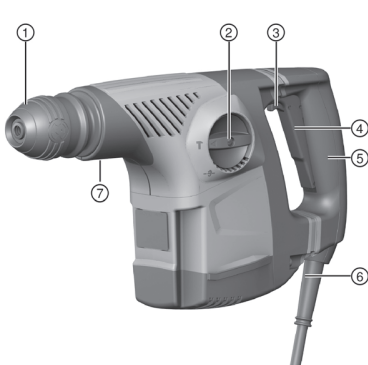

- ① TE-C or TE-T chuck
- ② Function selector switch
- ③ Control switch lock
- ④ Control switch
- ⑤ Grip
- ⑥ Supply cord
- ⑦ Front gripping surface



3.2 Intended use

The product described is an electrically powered breaker. It is designed for light chiseling work on masonry and surface finishing work on concrete.

- ▶ Operation is permissible only when connected to a power source providing a voltage and frequency in compliance with the information given on the type identification plate.

3.3 Active Vibration Reduction (AVR)

This product is equipped with an Active Vibration Reduction (AVR) system, which reduces vibration significantly.

3.4 Items supplied

Breaker, operating instructions.



Other system products approved for use with this product can be found at your local **Hilti Store** or at: www.hilti.group

4 Technical data

4.1 Breaker

When powered by a generator or transformer, the generator or transformer's power output must be at least twice the rated input power shown on the rating plate of the power tool. The operating voltage of the transformer or generator must always be within +5% and -15% of the rated voltage of the power tool.

The information given applies to a rated voltage of 230 V. The data may vary in the event of deviations from the rated voltage and for country-specific versions. Please refer to the power tool's rating plate for details of its voltage, frequency, current and input power ratings.

	TE 300-AVR
Weight in accordance with EPTA procedure 01	3.8 kg
Single impact energy in accordance with EPTA procedure 05/2009	3.3 J

4.2 Noise information and vibration values in accordance with EN 62841

The sound pressure and vibration values given in these instructions were measured in accordance with a standardized test and can be used to compare one power tool with another. They can also be used for a preliminary assessment of exposure.

The data given represent the main applications of the power tool. However, if the power tool is used for different applications, with different accessory tools, or is poorly maintained, the data can vary. This can significantly increase exposure over the total working period.

An accurate estimation of exposure should also take into account the times when the power tool is switched off, or when it is running but not actually being used for a job. This can significantly reduce exposure over the total working period.

Identify additional safety measures to protect the operator from the effects of noise and/or vibration, for example: maintaining the power tool and accessory tools, keeping the hands warm, organization of work patterns.

Noise information

Measured sound power level (L_{WA})	100 dB(A)
Sound pressure level (L_{pA})	89 dB(A)
Uncertainty (noise values) (K_{pA} and K_{WA})	3 dB(A)

Total vibration

Chiseling in concrete ($a_{h, Cheq}$)	11 m/s ²
Uncertainty (total vibration) (K)	1.5 m/s ²



5 Operation

<p>Fitting / removing the accessory tool</p> <p> WARNING</p> <p>Risk of injury! The accessory tool gets hot during use and may also have sharp edges.</p> <ul style="list-style-type: none"> ▶ Wear protective gloves when changing the tool. <hr/> <p> Check the accessory tool for damage or uneven wear each time before use and replace it if necessary.</p> <p> Use only the recommended grease supplied by Hilti. Use of unsuitable grease may cause damage to the product.</p>	2
<p>Removing / fitting the chuck</p>	3
<p>Positioning the chisel </p> <p> The chisel can be adjusted to 12 different positions (in 30° increments). This ensures that flat chisels and shaped chisels can always be set to the optimum working position.</p>	4
<p>Locking the chisel </p>	
<p>Chiseling </p>	5
<p>Fitting the needle adapter</p> <p> CAUTION</p> <p>Risk of injury! Use of the needle adapter in an incompatible tool is hazardous.</p> <ul style="list-style-type: none"> ▶ Use the needle adapter only with the TE 300-AVR. <hr/> <p> WARNING</p> <p>Risk of injury! Risk of pinching the fingers</p> <ul style="list-style-type: none"> ▶ Wear protective gloves when fitting the needle adapter. 	6
<p>Removing the needle adapter</p> <p> WARNING</p> <p>Risk of injury! The accessory tool gets hot during use and may also have sharp edges.</p> <ul style="list-style-type: none"> ▶ Wear protective gloves when changing the tool. 	7
<p>Selecting / adjusting the needle guide</p> <p> WARNING</p> <p>Risk of injury! The accessory tool gets hot during use and may also have sharp edges.</p> <ul style="list-style-type: none"> ▶ Wear protective gloves when changing the tool. <hr/> <p> The needle guide is interchangeable and adjustable. Round or oval versions are available for working on surfaces, edges or corners.</p>	8
<p>Changing the needle cage and needles</p> <p> WARNING</p> <p>Risk of injury! The accessory tool gets hot during use and may also have sharp edges.</p> <ul style="list-style-type: none"> ▶ Wear protective gloves when changing the tool. <hr/> <p> The spring pre-tensioner separates the needle holder from the locking mechanism. The needles can be replaced individually or as a complete set.</p>	9

6 Care and maintenance

<p> WARNING</p> <p>Electric shock hazard! Attempting care and maintenance with the supply cord connected to a power outlet can lead to severe injury and burns.</p> <ul style="list-style-type: none"> ▶ Always unplug the supply cord before carrying out care and maintenance tasks.



Care

- Carefully remove stubborn dirt from the tool.
- Clean the air vents carefully with a dry brush.
- Use only a slightly damp cloth to clean the casing. Do not use cleaning agents containing silicone as they can attack the plastic parts.

Maintenance



WARNING

Danger of electric shock! Improper repairs to electrical components may lead to serious injuries including burns.

- ▶ Repairs to the electrical section of the tool or appliance may be carried out only by trained electrical specialists.
-
- Check all visible parts and controls for signs of damage at regular intervals and make sure that they all function correctly.
 - Do not operate the product if signs of damage are found or if parts malfunction. Have it repaired immediately by **Hilti Service**.
 - After cleaning and maintenance, fit all guards or protective devices and check that they function correctly.



To help ensure safe and reliable operation, use only genuine Hilti spare parts and consumables. Spare parts, consumables and accessories approved by Hilti for use with the product can be found at your local **Hilti Store** or online at: www.hilti.group.

7 Troubleshooting

If the trouble you are experiencing is not listed in this table or you are unable to remedy the problem by yourself, please contact **Hilti Service**.

Trouble or fault	Possible cause	Action to be taken
The breaker doesn't start.	Interruption in the electric supply.	▶ Plug in another electric tool or appliance and check whether it works.
No hammering action.	The power tool is too cold.	▶ Bring the tip of the accessory tool into contact with the working surface, switch the power tool on and allow it to run. If necessary, repeat the procedure until the hammering mechanism begins to operate.
The breaker doesn't achieve full power.	The extension cord is too long or its gauge is inadequate.	▶ Use an extension cord of an approved length and/or of adequate gauge.
	The control switch is not fully pressed.	▶ Press the control switch as far as it will go.
The chisel cannot be released from the chuck.	The chuck is not pulled back fully.	▶ Pull the tool lock back as far as it will go and remove the accessory tool.

8 Disposal

Most of the materials from which **Hilti** tools and appliances are manufactured can be recycled. The materials must be correctly separated before they can be recycled. In many countries, your old tools, machines or appliances can be returned to **Hilti** for recycling. Ask **Hilti Service** or your Hilti representative for further information.



- ▶ Do not dispose of power tools, electronic equipment or batteries as household waste!





EC Declaration of Conformity | UK Declaration of Conformity



Manufacturer:
Hilti Corporation
Feldkircherstraße 100
4994 Schaan | Liechtenstein

UK Importer:
Hilti (Gt. Britain) Limited
No. 1 Circle Square, 3 Symphony Park
Manchester, England, M1 7FS

TE 300-AVR (01)

Serial Numbers: 1-9999999999

2006/42/EC | Supply of Machinery (Safety) Regulations 2008

EN 62841-1:2015, AC:2015

EN IEC 62841-2-6:2020/A11:2020

2014/30/EU | Electromagnetic Compatibility Regulations 2016

EN IEC 55014-1:2021

EN IEC 55014-2:2021

2011/65/EU | The Restriction of the Use of Certain Hazardous Substances in Electrical and Electronic Equipment Regulations 2012

EN IEC 61000-3-2:2019, A1:2021

EN 61000-3-3:2013 + A1:2019

2000/14/EC | Noise Emission in the Environment by Equipment for use Outdoors Regulations 2001

Details to 2000/14/EC | Noise Emission in the Environment by Equipment for use Outdoors Regulations 2001:

Measured sound power level L_{wM} : 102 dB/1pW

Guaranteed sound power level, L_{wM} : 105 dB/1pW

Conformity assessment procedure: 2000/14/EC Annex VI | Noise Emission in the Environment by Equipment for use Outdoors Regulations 2001, Schedule 9

EU Notified Body: TÜV NORD CERT GmbH
Am TÜV 1, 45307 Essen, Germany (CE 0044)

UK Approved Body: HORIBA MIRA Certification Ltd
Walling Street, Nuneaton, Warwickshire CV10 0TU (No 0888)

Dr. Tahar Zrilli
Head of Quality and Process Management
Business Area Electric Tools & Accessories

Schaan, 08.02.2023

Edward-Louis Przybyłowicz
Head of BU Power Tool & Accessories
Business Area Electric Tools & Accessories



Hilti Corporation
LI-9494 Schaan
Tel.:+423 234 21 11
Fax:+423 234 29 65
www.hilti.group

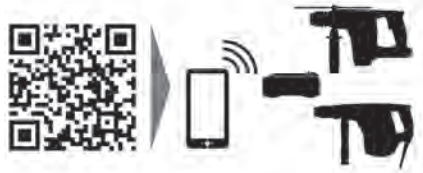

401138