



Ⓒ GB Operators Manual

4



MINIMIX 150

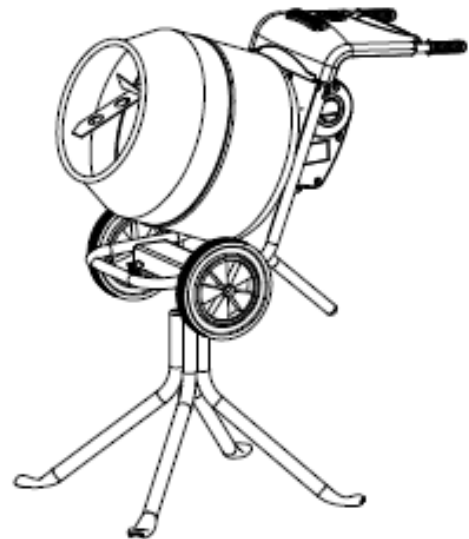

- Spare Parts Book

14

**EC DECLARATION OF CONFORMITY / DECLARATION CE DE CONFORMITE /
DECLARACIÓN DE CONFORMIDAD CE / DECLARAÇÃO CE DE CONFORMIDADE /
EG-VERKLARING VAN OVEREENSTEMMING / EF
OVERENSSTEMMELSESERKLÆRING**

(GB) We, Belle Group Sheen UK, Sheen, Nr. Buxton, Derbyshire, SK17 0EU, GB, hereby certify that if the product described within this certificate is bought from an authorised Belle Group dealer within the EEC, it conforms to the following EEC directives: 98/37/EC (This directive is a consolidation of the original machinery directive 89/392/EEC), Electromagnetic Compatibility Directive 89/336/EEC (as amended by 92/31/EEC & 93/68/EEC). The low voltage directive 73/23/EEC, BS EN ISO 12100-1:2003 Safety of machinery and associated harmonised standards, where applicable. Noise emissions conform to directive 2000/14/EC Annex VI, for machines under article 12 the notified body is AV Technology Limited, AVTECH house, Birdhall Lane, Cheadle Heath, Stockport, Cheshire, SK3 0XU, GB.
Noise Technical Files are held at the Belle Group Head Office address which is stated above.

(F) Nous soussignés, Belle Group Sheen UK, Sheen, Nr Buxton, Derbyshire, SK17 0EU, GB, certifions que si le produit décrit dans ce certificat est acheté chez un distributeur autorisé Belle Group au sein de la CEE, il est conforme aux normes CEE ci-après: 98/37/CE (Cette norme est une codification des normes de la machine d'origine 89/392/CEE), Norme compatible pour électromagnétisme 89/336/CEE (modifié par 92/31/CEE et 93/68/CEE). Caractéristiques basse tension 73/23/CEE, BS EN ISO 12100-1:2003, Norme de sécurité des machines et des critères associés et configurés, si applicable. Les émissions de bruit sont conformes à la directive 2000/14/EC Annexe VI pour machines, article 12, l'objet mentionné est AV Technology Limited, AVTECH House, Birdhall Lane, Cheadle Heath, Stockport, Cheshire, SK3 0XU, GB.
Les dossiers techniques sur les émissions sonores des machines sont détenus au siège social de BELLE GROUP à l'adresse ci-dessus.

(E) La Sociedad, Belle Group Sheen UK, Sheen, Nr. Buxton, Derbyshire, SK 17 0EU, GB, por el presente documento certifica que si el producto descrito en este certificado es comprado a un distribuidor autorizado de Belle Group en la CEE, este es conforme a las siguientes directivas: 98/37/CE de la CEE (Esta directiva consolida la directiva inicial sobre maquinaria 89/392/CEE), Directiva 89/336 CEE sobre Compatibilidad Electromagnética (según enmiendas 92/31/CEE y 93/68 CEE), Directiva sobre Bajo Voltaje 73/23/CEE, BS EN ISO 12100-1:2003 de Seguridad de Maquinaria y Niveles armonizados estándares asociados donde sean aplicables. Emisión de Ruidos conforme a la Directiva 2000/14/CE Anexo VI para máquinas bajo artículo 12 la mencionada unidad está AV Technology Limited, AVTECH House, Birdhall Lane, Cheadle Heath, Stockport, Cheshire, SK3 0XU, GB.
En La Sede Central de Belle Group existen Archivos Técnicos con contenido referente a Niveles de Ruido.

(P) O signatário, Belle Group Sheen UK, Sheen, Nr Buxton, Derbyshire, SK 0EU, GB, pelo presente, declara que se o produto descrito neste certificado foi adquirido a um distribuidor autorizado do Belle Group em qualquer país da UE, está em conformidade com o estabelecido nas seguintes diretivas comunitárias: 98/37/EC (esta directiva é uma consolidação da directiva de maquinaria 89/392/EEC), Directiva de Compatibilidade Electromagnética 89/336/EEC (conforme corrigido pelas 92/31/EEC & 93/68 EEC). A directiva de baixa voltagem 73/23/EEC, BS EN ISO 12100-1:2003 Segurança da maquinaria e às normas harmonizadas afins se aplicáveis. As emissões de ruído respeitam e estão dentro das directivas para máquinas 2000/14/EC Anexo VI, artigo 12, sendo o organismo notificado AV Technology Limited, AVTECH house, Birdhall Lane, Cheadle Heath, Stockport, Cheshire, SK3 0XU, GB.
A informação técnica sobre níveis sonoros está disponível na Sede da Belle Group na morada acima mencionada.

(NL) Ondergetekende, Belle Group Sheen UK, Sheen, Nr. Buxton, Derbyshire, SK17 0EU, GB, verklaaren hierbij dat als het product zoals beschreven in dit certificaat is gekocht van een erkende Belle Group dealer binnen de EEG, het voldoet aan de volgende EEG richtlijnen: 98/37/EC (Deze richtlijn is een opvolger van de originele Machineryrichtlijn 89/392/EEG), Electromagnetische Compatibiliteit Richtlijn 89/336/EEG (geamendeerd door 92/31/EEG & 93/68 EEC). De Laagspannings Richtlijn 72/23/EEG, BS EN ISO 12100-1:2003 Veiligheid van Machines en hieraan gekoppelde geharmoniseerde Standaarden, waar deze van toepassing is. Rumoer emissies passen voor richtlijn EC Zjgebouw VI, voor toestel onder stuk 12 naar de notified groep zit AV Technology Limited, AVTECH house, Birdhall Lane, Cheadle Heath, Stockport, Cheshire, SK3 0XU, GB
Worden de Technische Dossiers van het lawaai gehouden op het adres van het Hoofdkantoor van de Groep Belle dat hierboven wordt verklaard.

(DK) Vi, Belle Group Sheen UK, Sheen, Nr. Buxton, Derbyshire, SK17 0EU, GB, erklærer hermed, at hvis det i dette certifikat beskrevne produkt er købt hos en autoriseret Belle Group forhandler i EU, er det i overensstemmelse med følgende EØF-direktiver: 98/37/EF, 73/23/EØF (som ændret ved 93/68/EØF), 89/336/EØF (som ændret ved 92/31/EØF), 93/68/EØF og tilknyttede, harmoniserede standarder, hvor relevant. Støjniveauet er i overensstemmelse med direktiv 2000/14/EF, bilag VI gældende for maskiner under paragraf 12. Det bemyndigede organ er AV Technology Limited, AVTECH house, Birdhall Lane, Cheadle Heath, Stockport, Cheshire, SK3 0XU, Storbritannien.
De tekniske støjspecifikationer forefindes på Belle Group's hovedkontor, adressen er skrevet ovenfor.

PRODUCT TYPE	TYPE DE PRODUIT.....	TIPO DE PRODUCTO	TIPO DE PRODUCTO
MODEL.....	MODELE	MODELO	MODELO.....
SERIAL No.....	N° DE SERIE	N° DE SERIE.....	NO. DE SÉRIE.....
DATE OF MANUFACTURE.	DATE DE FABRICATION	FECHA DE FABRICACIÓN..	DATA DE FABRIC
SOUND POWER LEVEL MEASURED..... (GUARANTEED).....	NIVEAU DE PUISSANCE SONORE MESUREE..... (GARANTIE).....	NIVEL DE POTENCIA ACÚSTICA MEDIDO..... (GARANTIZADO).....	NIVEL DE POTÊNCIA DE SOM MEDIDO..... (GARANTIDO).....
WEIGHT.....	PODS.....	PESO.....	PESO.....
PRODUCTTYPE.....	PRODUKTTYPE.....		
MODEL.....	MODEL.....		
SERIENUMMER.....	SERIENR.....		
FABRICATEDATUM.....	FREMSTILLINGSDATO.....		
GEMETEN GELUIDSTERKTEN/NEAU (GEGARANDEERD).....	LYEFFEKTNIVEAU MÅLT		
GEWICHT.....	VEGT.....		



Signed by:
Signature:
Medido por:
Assinado por:
Getekend door:
Underskrevet af:

Ray Neilson

Managing Director - On behalf of BELLE GROUP (SHEEN) UK.
Le Directeur Général - Pour le compte de la SOCIETE BELLE GROUP (SHEEN) UK.
Director Gerente - En nombre de BELLE GROUP (SHEEN) UK.
Director-Geral - Em nome de BELLE GROUP (SHEEN) UK.
Algemeen Directeur - Namens BELLE GROUP (SHEEN) UK.
Administrerende direktør - På vegne af BELLE GROUP (SHEEN) UK.



Introduction

Congratulations on your purchase of this quality concrete mixer from the Belle Group Range.

This machine is manufactured to conform to the EEC directives currently in force, is issued with a Declaration of Conformity and therefore displays the CE mark, applicable in territories where they are enforced. Retain this manual with your machine for future reference.

SAFETY AND ACCIDENT PREVENTION

Operation Instructions

All persons who apply, assemble, operate, start, control, maintain or repair this machine, must read and understand the operating instructions.

Owner Responsibility:

The owner must ensure that only qualified persons operate, maintain or repair this machine.

STORAGE

When not in use, store in a dry, locked place. Keep away from children.

Operation for the Intended Purpose :

Mixers are intended for the production of concrete, mortar and plaster. The mixer must be used for its intended purposes and is not suitable for the mixing of flammable or explosive substances. The mixers must not be used in an explosive atmosphere.

MAINTENANCE AND REPAIRS

When maintaining this machine only the manufacturers original replacement parts may be used.

The user will lose any possible claims if replacement parts used are other than the makers original replacement parts.

Only authorised persons should repair the mixer, and within the requirements of the CE mark (where applicable), where no deviation to the original specification must take place.



CAUTION

Any maintenance and repairs carried out, to any of the electric components must be undertaken by a qualified electrician.



WARNING



WARNING

Before you operate or carry out any maintenance on this machine **YOU MUST READ** and **STUDY** this manual.

KNOW how to safely use the unit's controls and what you must do for safe maintenance.

(Be sure that you know how to switch the machine off before you switch on, in case you get into difficulty.)

ALWAYS wear or use the proper safety items required for your personal protection.

If you have **ANY QUESTIONS** about the safe use or maintenance of this unit, **ASK YOUR SUPERVISOR OR CONTACT THE BELLE GROUP +44 (0)1298 84606**



Contents

Introduction	4
Warning	4
Technical Data	5
Functional Controls	6
Safety Instructions	7
Warning Decals	8
Assembly Instructions	8
Stand Assembly.....	9
Loading & Unloading	9
Service & Maintenance	10 - 12
Mixing Hints	13
Warranty	13



Introduction

Congratulations on your purchase of this quality concrete mixer from the Belle Group Range.

This machine is manufactured to conform to the EEC directives currently in force, is issued with a Declaration of Conformity and therefore displays the CE mark, applicable in territories where they are enforced. Retain this manual with your machine for future reference.

SAFETY AND ACCIDENT PREVENTION

Operation Instructions

All persons who apply, assemble, operate, start, control, maintain or repair this machine, must read and understand the operating instructions.

Owner Responsibility:

The owner must ensure that only qualified persons operate, maintain or repair this machine.

STORAGE

When not in use, store in a dry, locked place. Keep away from children.

Operation for the Intended Purpose :

Mixers are intended for the production of concrete, mortar and plaster. The mixer must be used for its intended purposes and is not suitable for the mixing of flammable or explosive substances. The mixers must not be used in an explosive atmosphere.

MAINTENANCE AND REPAIRS

When maintaining this machine only the manufacturers original replacement parts may be used.

The user will lose any possible claims if replacement parts used are other than the makers original replacement parts.

Only authorised persons should repair the mixer, and within the requirements of the CE mark (where applicable), where no deviation to the original specification must take place.



CAUTION

Any maintenance and repairs carried out, to any of the electric components must be undertaken by a qualified electrician.



WARNING



WARNING

Before you operate or carry out any maintenance on this machine **YOU MUST READ** and **STUDY** this manual.

KNOW how to safely use the unit's controls and what you must do for safe maintenance.

(Be sure that you know how to switch the machine off before you switch on, in case you get into difficulty.)

ALWAYS wear or use the proper safety items required for your personal protection.

If you have **ANY QUESTIONS** about the safe use or maintenance of this unit, **ASK YOUR SUPERVISOR OR CONTACT THE BELLE GROUP +44 (0)1298 84606**



Contents

Introduction	4
Warning	4
Technical Data	5
Functional Controls	6
Safety Instructions	7
Warning Decals	8
Assembly Instructions	8
Stand Assembly.....	9
Loading & Unloading	9
Service & Maintenance	10 - 12
Mixing Hints	13
Warranty	13

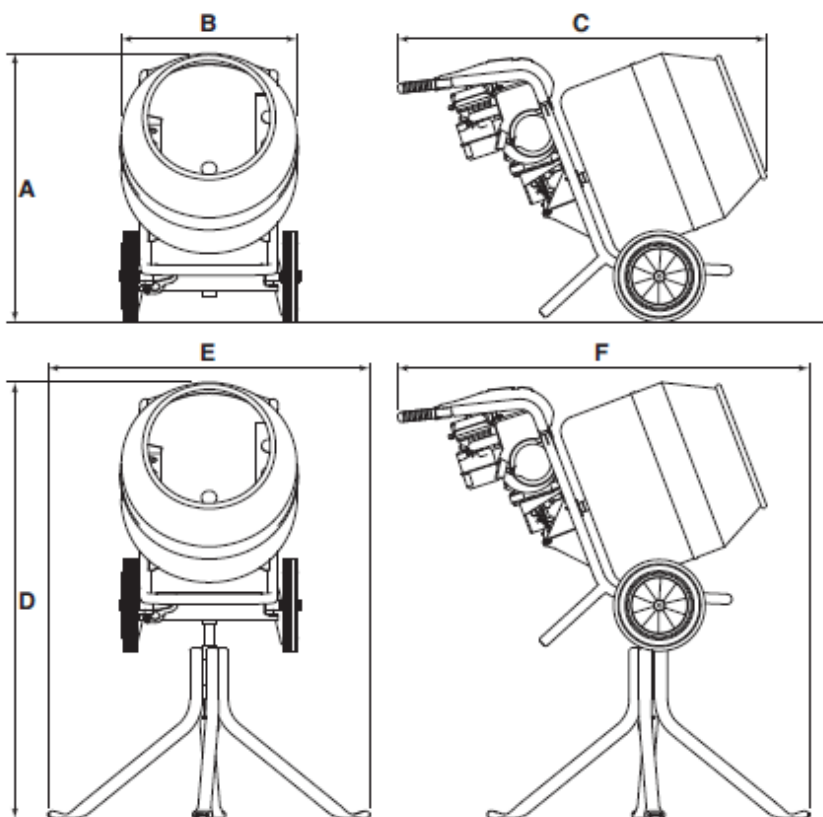
Technical Data

All Models		Minimix 150			
A - Height (Off Stand)		890 mm			
B - Width (Off Stand)		597 mm			
C - Length (Off Stand)		1211 mm			
D - Height (On Stand)		1432 mm			
E - Width (On Stand)		1056.5 mm			
F - Length (On Stand)		1227 mm			
Electric Models	110v 50Hz	230v 50Hz	230v 60Hz	415v 50Hz	
Unladen Weight	55.5 Kg	55 Kg	55 Kg	57 Kg	
Stand Weight	9.5 Kg	9.5 Kg	9.5 Kg	9.5 Kg	
Maximum Drum Capacity	130 ltr	130 ltr	130 ltr	130 ltr	
Maximum Mixing Capacity	90 ltr	90 ltr	90 ltr	90 ltr	
Drum speed (RPM)	24	24	24	24	
Nominal Voltage	110v	230v	230v	415v	
Nominal Current	5.0amp	2.6amp	3.0amp	1.0amp	
Nominal Power	0.55 kW	0.55 kW	0.6 kW	0.55 kW	
Current Frequency	50Hz	50Hz	60Hz	50Hz	
Motor R.P.M.	2850	2850	3480	2780	
Protective System	IP45	IP45	IP45	IP45	
Power Consumption	550 W	550 W	670 W	550 W	
Sound Power Level	84 dB(A)	84 dB(A)	84 dB(A)	84 dB(A)	
Petrol Models	Briggs & Stratton	Honda GXH50	Honda GX120	Robin EH09DU	
Unladen Weight	60.5 Kg	53.5 Kg	61 Kg	60.5 Kg	
Stand Weight	9.5 Kg	9.5 Kg	9.5 Kg	9.5 Kg	
Maximum Drum Capacity	130 ltr	130 ltr	130 ltr	130 ltr	
Maximum Mixing Capacity	90 ltr	90 ltr	90 ltr	90 ltr	
Drum speed (RPM)	24	24	5 - 24	24	
Engine Model	2.4hp Vanguard	GXH 50	GX120	EH09	
Fuel Type	Petrol	Petrol	Petrol	Petrol	
Nominal Power	1.8 kW	1.8 kW	2.9	2.1 kW	
Sound Power Level	92 dB(A)	92 dB(A)	92 dB(A)	92 dB(A)	



Functional Controls

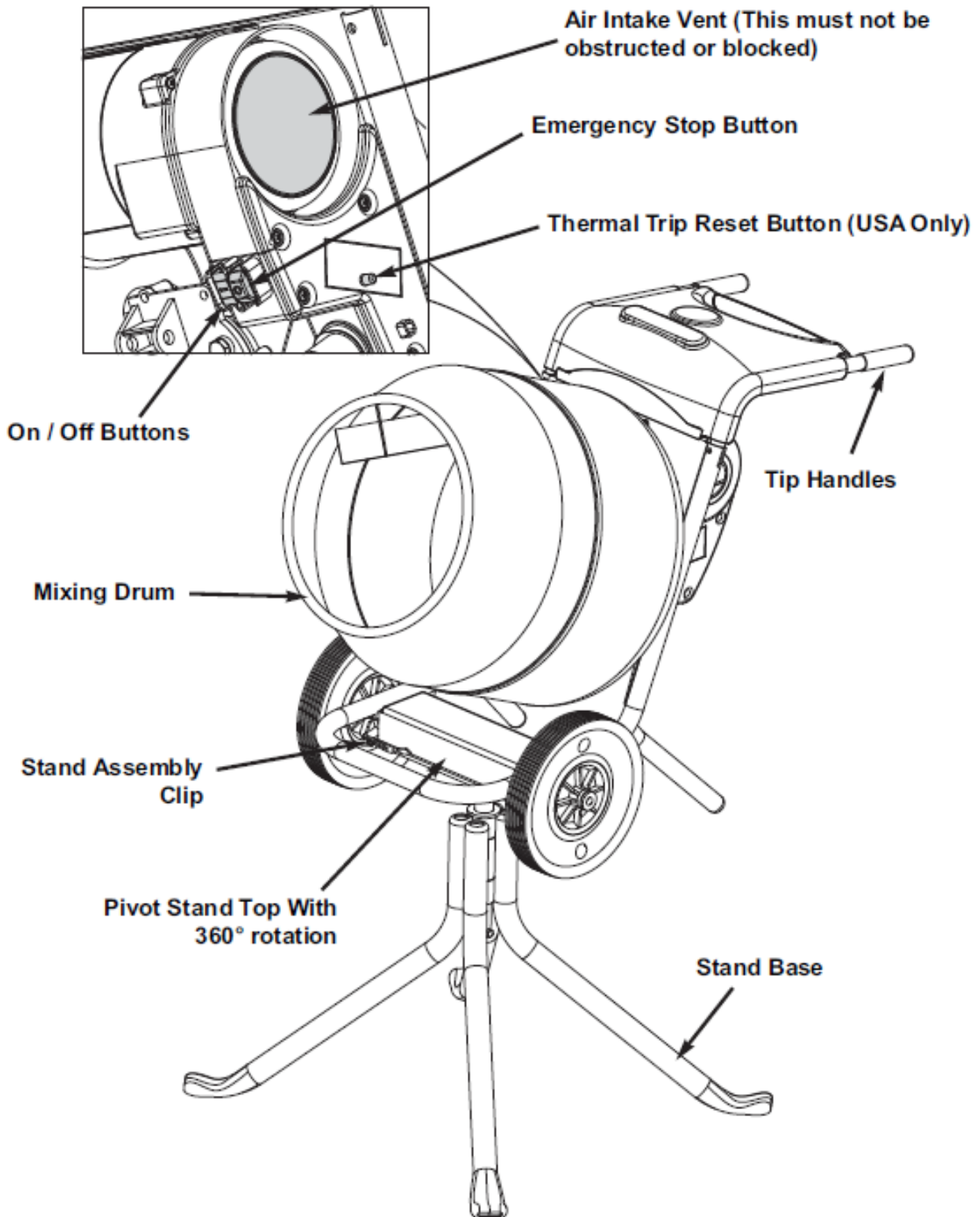

Safety Instructions



Before starting the mixer

- ⚠ Ensure engine oil is filled to correct level before operating mixer. **Note:** The engine must be lifted to the horizontal position when filling and checking oil.
- ⚠ Check that all guards are in position and correctly fitted.
- ⚠ **DO NOT** wear loose clothing or jewellery that may become entangled in the workings of this machine.
- ⚠ Suitable clothing as follows should meet relevant EEC/local safety standards: overalls, work boots, goggles, face mask, gloves and ear defenders etc.
- ⚠ **DO NOT** tip mixer onto the drum mouth when motor is running.
- ⚠ Ensure that any trailing cable is protected against damage and not liable to be tripped over or trapped underneath the mixer.
- ⚠ **We recommend the use of an Residual Current Device on 230v electrics.**
- ⚠ Remove all packaging material before operating.

When operating the mixer

- ⚠ Keep unauthorised persons away from mixing drum.
- ⚠ Keep area around the mixer clear of obstructions which could cause persons to fall onto moving parts.
- ⚠ Always ensure mixer is on level ground before mixing.
- ⚠ **DO** become familiar with the controls before operating this machine.
- ⚠ **DO** ensure that all guards are fitted in the correct position.
- ⚠ **DO** ensure plenty of ventilation when running diesel/petrol engines in a confined area.
- ⚠ **DO** replace any worn/damaged warning decals.
- ⚠ **DO** ensure the drum is rotating while emptying the mixer.
- ⚠ **DO** always switch off and remove the plug from the socket if leaving the machine unattended.
- ⚠ **DO NOT** use as a wheel barrow. Disconnect from power supply before moving.
- ⚠ **BEWARE** of the Danger Zones & Hot Zones.
- ⚠ **BE AWARE** of exhaust venting directions.

Emergency Stop

If you have to turn off the mixer in a emergency you must: Electric: either turn off at switch or at the mains, Petrol: turn the engine switch off, see engine manual.

Fire Fighting

If your mixer catches fire, turn off the electric supply. Using a dry powder or CO2 fire extinguisher put out the fire. If the fire can not be put out, keep away and call the fire brigade. If you are in any doubt about the safety condition of your machine, please contact your Belle authorized Service Dealer.

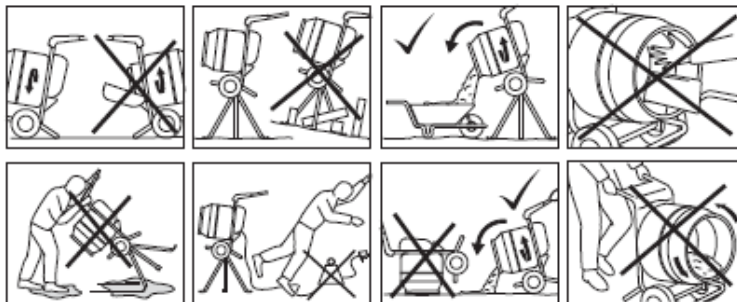

Warning - Important

Should the socket outlets in your home not be suitable for the plug supplied with your product, the plug must be removed (cut-off if it is a moulded plug and disposed of) and an appropriate plug fitted. Follow wiring instructions carefully. Do not connect either core to the earth pin, as this is a Class II Isolated Product.

BLUE = NEUTRAL & BROWN = LIVE

As the colours of the wires in the mains lead of this appliance may not correspond with the coloured markings identifying the terminals in your plug, proceed as follows:

The wire which is coloured Blue must be connected to the terminal which is marked with the letter N or coloured Black. The wire which is coloured Brown must be connected to the terminal which is marked with the letter L or coloured Red.

Warning Decals



Warning!



Caution Taken When Handling.



Wear Ear Protection.



Fire and Explosive Risk.



Wear Eye Protection.



Wear Protective Footwear.



Read Operators Manual.



Do Not Hang.



This Way Up.



Only Stack 3 High.

STACK

Honda GX120 Engine Only:-



Position Of The Engine
Emergency Stop Switch.

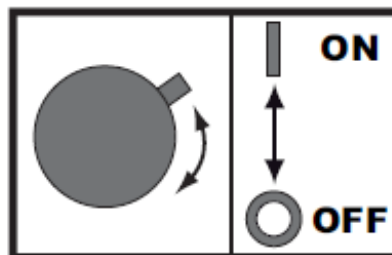

Emergency Stop Switch
Operating Instructions.

Assembly Instructions

Ensure drum fits right up to the shoulder on the shaft. Do not spin on fast as this may damage the gearbox

Tools Required:-
 13mm x1
 x1

Electric Only

Ensure all nuts and bolts are securely tight

PARALLEL

Please Note: Supplied with no oil in petrol engine use bottle provided for initial engine fill

Emergency Stop Button
(Electric Only)

Stand Assembly

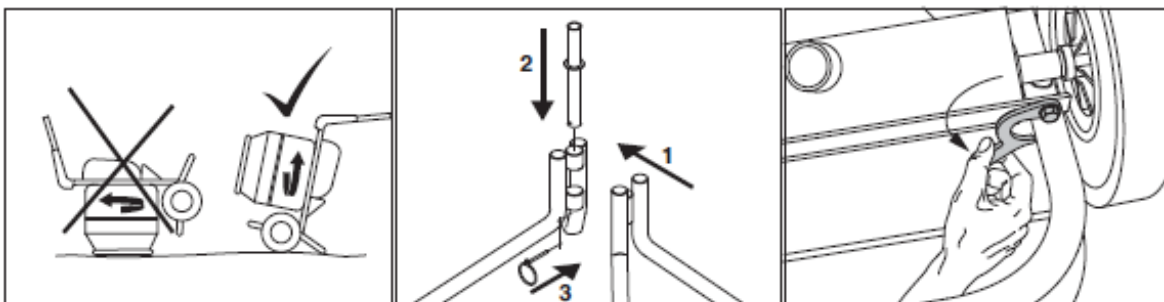

DO NOT Tip mixer onto drum mouth when the motor is running

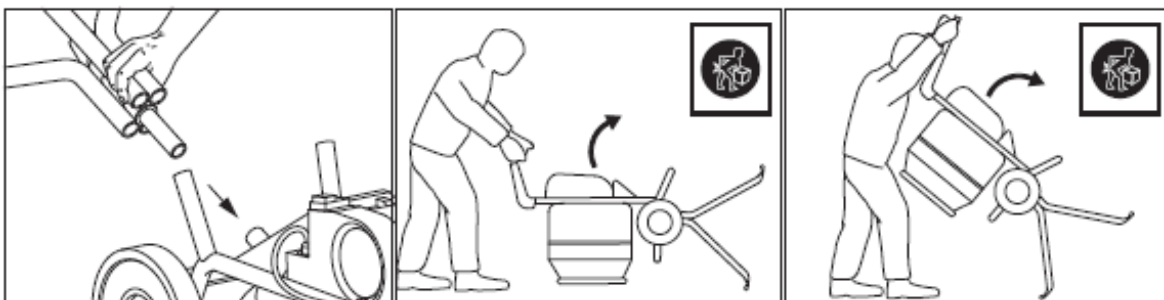

CAUTION whilst rotating the mixer up into the stand position, always lift from the front of the mixer.



NOTE: When ready for dismantling the mixer after use, follow all the previous procedures but in reverse order. Ensure Stand Clip is located correctly onto frame.

Loading and Unloading

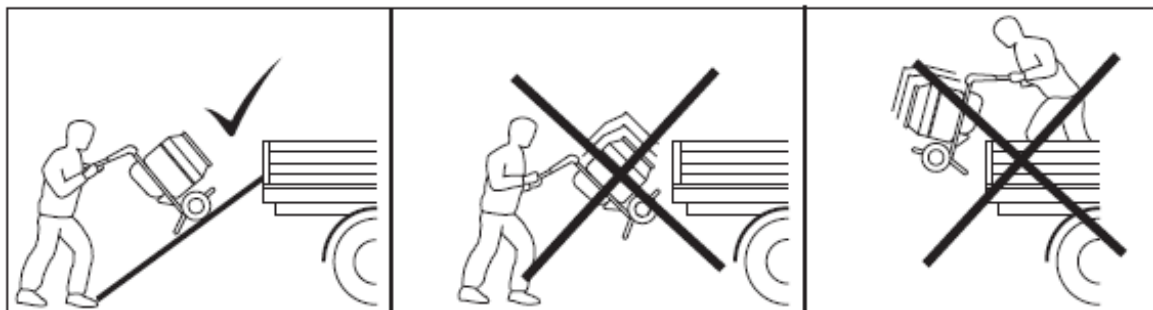

CAUTION

Never remain under or in the immediate vicinity of the machine when it is lifted by a crane. Only use marked lifting points. Always make sure that all lifting devices are dimensioned for the weight of the products.



Service and Maintenance

Before starting any maintenance or repairs, switch off motor, and isolate from the main power supply.
On completion of maintenance, check that the mixer functions correctly and that all guards are correctly fitted.

ELECTRIC MIXER

All portable electric appliances are dangerous if abused. This machine will only operate on one voltage. Check the power supply to ensure it corresponds to the voltage as indicated on the rating label.

Make sure that the motor is switched off before you plug it into the power supply.

230v - Always use a Residual Current Device ("RCD"), (earth leakage trip), plugged directly into the 230v socket. If using an extension cable, plug it directly into the RCD.

110v - When using a portable transformer it must have a minimum output of 2.5kw and to continuous rated. Always use an RCD between the 230V supply and the portable transformer.

The symbols on the ON/OFF switch are 0 (Red) = OFF and I (Green) = ON in accordance with international standards.



WARNING

DO NOT use an extension cable between the transformer and the power supply. Always ensure that the cable between the 110v mixer and transformer is a minimum length of 3 metres. Ensure cable is fitted with cable clip to the mixer frame at all times.

EXTENSION CABLES

If you need to use an extension cable it must be no longer than 30 metres (100 feet) in length. The wire section must be 1.5mm² on 230v and 2.5mm² on 110v. Ensure that the extension cable is carefully laid out avoiding liquids, sharp edges and places where vehicles might run over it. Avoid allowing the extension cable to be trapped underneath the mixer. Unroll it fully or it will overheat and could catch fire. Make sure that any extension cable connections are dry and safe.

THERMAL PROTECTION DEVICE

The Electric motor is fitted with a Thermal Protection Device. Should circumstances arise where this activates, the motor will stop. Once the thermal trip resets itself the motor will be able to be restarted at the on/off switch. The thermal trip reset time could vary from 2 minutes to 10 minutes.

COMBUSTION ENGINES

Check oil regularly, level engine up when doing so. For Initial engine fill or top up use a suitable engine oil of a 10W/30 grade. In your own interests read the makers instruction leaflet issued with the machine before starting up.

If the safety facilities are damaged or don't function correctly the mixer must not be used. Be aware of exhaust venting directions, all exhausts vent to the left hand side of the machine when viewed from the rear of the machine. To maintain correct lubrication the mixer must always be opened on level ground. Always read the engine manufacturers manual before starting the engine. Ensure plenty of ventilation when running the gasoline engines in a confined area. Beware of hot parts.

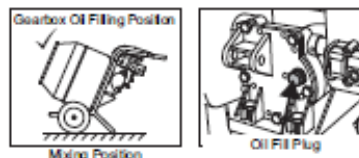
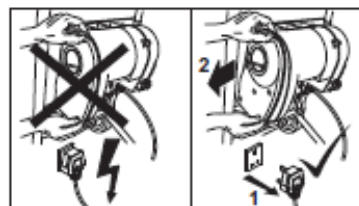

NOTE:- ONLY HONDA GX120 VARIANTS HAVE A VARIABLE THROTTLE. SEE ENGINE MANUAL FOR MORE DETAILS.

CLEANING

Wipe off any external material. **DO NOT** use petrol, turpentine, lacquer or paint thinner, dry cleaning fluids or similar products. Never let any liquids near the engine/motor. Use 1" gravel and clean water to clean the inside of the drum. **DO NOT** use bricks etc. as this will damage the drum.

FRAME

The hole on the underside of the frame is to drain away any water.

BELT



WARNING

All Belle mixers Electric/Petrol are fitted with a preset tensioned toothed belt. No adjustment is necessary. **DO NOT** try to adjust with the motor running. Ensure the extension lead is always unplugged before the motor cover is removed.

GEARBOX

The factory has preset the gearbox oil level. Before inspecting the gearbox oil level, make sure the gearbox is cold before removing the filler plug. Top up with EP90 or similar gear oil in the mix position to the level of the filler plug.

Service and Maintenance GB

Switch Check Flow-Chart

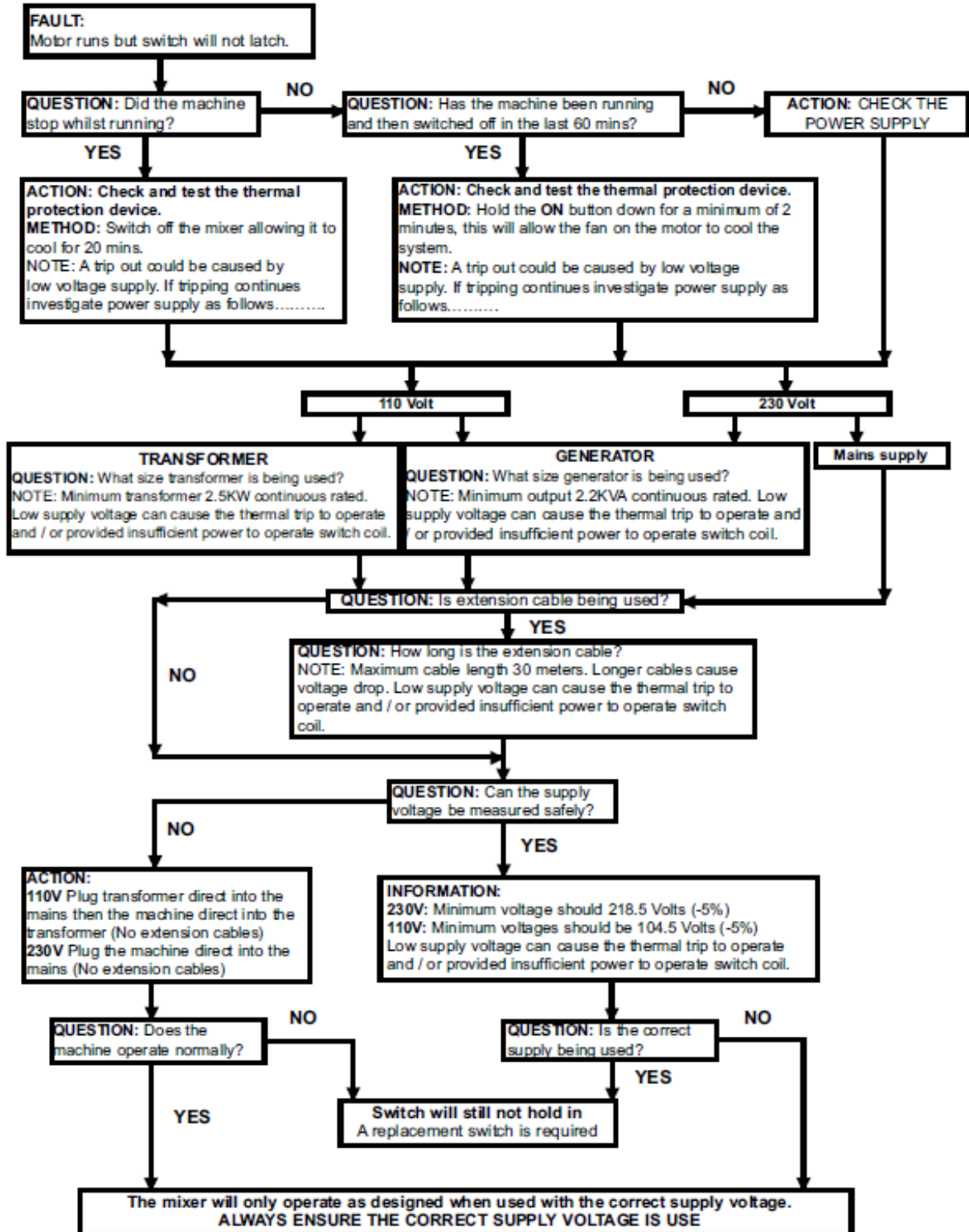



Mixing Hints

Mix Ratios

The correct mix ratio (cement:sand:stone) depends on the type of application; harder concrete requires more cement, rougher applications require more aggregate. The ratios given below are guidelines: best proportions may depend on the quality of sand/stone used.

First put in the water - around 7 litres (1½ gallons), using more or less depending on the type of mix required. Add some aggregate before adding cement, to avoid sticking. Work consistently to the ratio of ingredients for whatever type of concrete mix you are working to.

Getting A Good Mix

The approximate mixing time for concrete is 2-4 minutes from when all the material (including the water) has been added - over-mixing can reduce strength and cause segregation of the coarser aggregates.

Beware of low grade aggregates; these will only lead to trouble later on with sinking and frost spoiling the appearance of the pour. Also do not get the concrete mix too wet as this can reduce strength and make it less able to withstand weathering.

Looking After Your Mixer

Never throw material into the mixer - trickle it steadily over the rim or it will stick firmly to the back of the drum and can only be dislodged by stopping the mixer.

Keep your mixer clean - material left in the drum will harden, and attract more on each use until the mixer is useless.

Do not throw bricks into a mixer drum to clean it out. The best method is a mix of 1" (2½cm) gravel and clean water - use plenty of it, as this will do the job in half the time.

APPLICATIONS	QUANTITIES		
	CEMENT	SAND	STONE
MOST ORDINARY	1	2	4
FOUNDATIONS	1	3	6
ROUGH MASS CONCRETE	1	4	8
WATERTIGHT FLOORS, TANKS PITS ETC.	1	1.5	3



Warranty

Your new Belle Group Minimix 150 is warranted to the original purchaser for a period of one-year (12 months) from the original date of purchase. The Belle Group warranty is against defects in design, materials and workmanship.

The following are not covered under the Belle Group warranty:

1. Damage caused by abuse, misuse, dropping or other similar damage caused by or as a result of failure to follow assembly, operation or user maintenance instructions.
2. Alterations, additions or repairs carried out by persons other than Belle Group or their recognised agents.
3. Transportation or shipment costs to and from Belle Group or their recognised agents, for repair or assessment against a warranty claim, on any machine.
4. Materials and/or labour costs to renew, repair or replace components due to fair wear and tear.

The following components are not covered by warranty.

- Drive Belt
- Engine air filter
- Engine spark plug

Belle Group and/or their recognised agents, directors, employees or insurers will not be held liable for consequential or other damages, losses or expenses in connection with or by reason of or the inability to use the machine for any purpose.

Warranty Claims

All warranty claims should firstly be directed to Belle Group, either by telephone, by Fax, by Email, or in writing.

For warranty claims:

Belle Group Warranty Department,
Sheen, Nr. Buxton
Derbyshire
SK17 0EU
England.

Tel : +44 (0)1298 84606,

Fax : +44 (0)1298 84722

Email : warranty@belle-group.co.uk

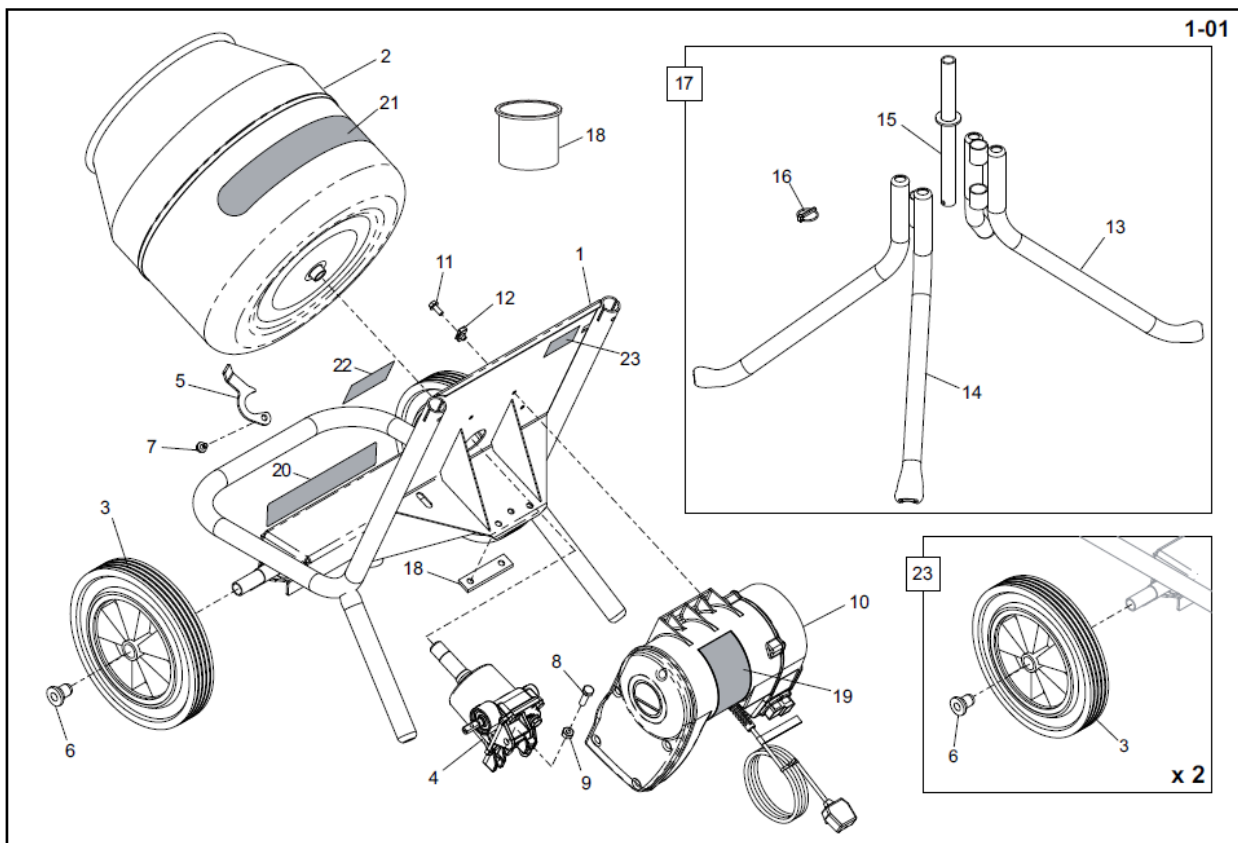

Frame Assembly, Ensemble Châssis, Cjto. Estructura, Montagem do Estrutura

1-01

1	900/24800	Frame	Châssis	Estructura	Estrutura	1
2	CMS12SP	Drum - Orange	Tambour - Orange	Tambor - Naranja	Tambor - Arancione	1
2	CMS12SPG2	Drum - Green	Tambour - Vert	Tambor - Verde	Tambor - Verde	1
2	CMS12SPR	Drum - Red	Tambour - Rouge	Tambor - Roja	Tambor - Vermelho	1
2	CMS12SPGR2	Drum - Grey	Tambour - Gris	Tambor - Gris	Tambor - Grey	1
3	60/0286	Wheel	Roue	Rueda	Roda	2
4	900/37600	Gearbox	Boîte de Vitesses	Caja de Engranajes	Caixa de Engrenagens	10/04 1
4	900/24700	Gearbox	Boîte de Vitesses	Caja de Engranajes	Caixa de Engrenagens	07/99, 10/04 1
5	900/99911	Stand Clip	Collier	Presilla	Grampo	1
6	900/11400	Wheel Retainer	Molette de Retenue	Retén - Rueda	Retentor - Roda	2
7	7/8045	Screw	Vis	Tornillo	Parafuso	M8 x 12 2
8	9/10005	Bolt	Boulon	Perno	Perno	M10 x 45 2
9	8/10009	Nut	Ecrou	Tuerca	Porca	M10 x 45 2
10	900/30100	Motor Kit	Kit De Moteur	Kit Motor	Kit do Motor	230v, 50Hz, UK 1
10	900/30300	Motor Kit	Kit De Moteur	Kit Motor	Kit do Motor	110v, 50Hz, UK 1
10	900/30500	Motor Kit	Kit De Moteur	Kit Motor	Kit do Motor	415v, 50Hz 1
11	7/8037	Screw	Vis	Tornillo	Parafuso	M8 x 20 2
12	8/8007	Nut	Ecrou	Tuerca	Porca	M8 2
13	900/17000	Stand Leg - Orange	Jambe De Quadripped - Orange	Pata Soporte - Naranja	Perna do cavalete - Arancione	2 x Boss 1
13	900/17000G2	Stand Leg - Green	Jambe De Quadripped - Verde	Pata Soporte - Verde	Perna do cavalete - Verde	2 x Boss 1
13	900/17000R	Stand Leg - Red	Jambe De Quadripped - Rouge	Pata Soporte - Roja	Perna do cavalete - Vermelho	2 x Boss 1
13	900/17000GR2	Stand Leg - Grey	Jambe De Quadripped - Gris	Pata Soporte - Gris	Perna do cavalete - Grey	2 x Boss 1
14	900/17100	Stand Leg - Orange	Jambe De Quadripped - Orange	Pata Soporte - Naranja	Perna do cavalete - Arancione	1 x Boss 1
14	900/17100G2	Stand Leg - Green	Jambe De Quadripped - Verde	Pata Soporte - Verde	Perna do cavalete - Verde	1 x Boss 1
14	900/17100R	Stand Leg - Red	Jambe De Quadripped - Rouge	Pata Soporte - Roja	Perna do cavalete - Vermelho	1 x Boss 1
14	900/17100GR2	Stand Leg - Grey	Jambe De Quadripped - Gris	Pata Soporte - Gris	Perna do cavalete - Grey	1 x Boss 1
15	900/26600	Stand Adaptor - Orange	Adaptateur De Quadripped - Orange	Adaptador Soporte - Naranja	Fixador do cavalete - Arancione	1
15	900/26600G2	Stand Adaptor - Green	Adaptateur De Quadripped - Verde	Adaptador Soporte - Verde	Fixador do cavalete - Verde	1
15	900/26600R	Stand Adaptor - Red	Adaptateur De Quadripped - Rouge	Adaptador Soporte - Roja	Fixador do cavalete - Vermelho	1
15	900/26600GR2	Stand Adaptor - Grey	Adaptateur De Quadripped - Gris	Adaptador Soporte - Grey	Fixador do cavalete - Gris	1
16	3/1007	Linch Pin	Goupille	Pasador	Pino	1
17	900/26500SP	Stand Assy - Orange	Quadripped - Orange	Ensamblaje Soporte - Naranja	Cavalete completo - Arancione	1
17	900/26500SPG2	Stand Assy - Green	Quadripped - Verde	Ensamblaje Soporte - Verde	Cavalete completo - Verde	1
17	900/26500SPR	Stand Assy - Red	Quadripped - Rouge	Ensamblaje Soporte - Roja	Cavalete completo - Vermelho	1
17	900/26500SPGR2	Stand Assy - Grey	Quadripped - Gris	Ensamblaje Soporte - Gris	Cavalete completo - Grey	1
18	900/99931	Support Plate	Plaque De Maintien	Placa sujección	Placa de suporte	10/02 1
18	1/0519	Paint (Orange)	Peinture (Orange)	Pintura (Naranja)	Pintura (Arancione)	1 Ltr 1
19	800/21250	Decal	Etiquette	Etiqueta	Etiqueta	230v, 50Hz (Euro 1) 1
19	800/21260	Decal	Etiquette	Etiqueta	Etiqueta	110v, 50Hz (Euro 1) 1
20	800/99953	Decal	Etiquette	Etiqueta	Etiqueta	Belle Group 1
20	800/99952	Decal	Etiquette	Etiqueta	Etiqueta	Belle Group 1
22	800/99809	Decal	Etiquette	Etiqueta	Etiqueta	Danger Zone 1
23	800/99780	Decal	Etiquette	Etiqueta	Etiqueta	GX120 Only 1
24	900/42200	Wheel Kit	Ensemble de Roue	Conjunto de Rueda	Conjunto da Roda	1

Power Unit Conversion Kits for Pre July '99 Machines.

-	900/36300	Motor Conversion Kit	Kit De Conversion De Moteur	Kit Conversor Motor	Conversor completo do motor	Honda GXH50	1
-	900/42300	Motor Conversion Kit	Kit De Conversion De Moteur	Kit Conversor Motor	Conversor completo do motor	Honda GX120	1
-	900/38200	Motor Conversion Kit	Kit De Conversion De Moteur	Kit Conversor Motor	Conversor completo do motor	Robin	1

Power Unit Conversion Kits for Post July '99 Machines.

-	900/38300	Motor Conversion Kit	Kit De Conversion De Moteur	Kit Conversor Motor	Conversor completo do motor	Robin	1
---	-----------	----------------------	-----------------------------	---------------------	-----------------------------	-------	---

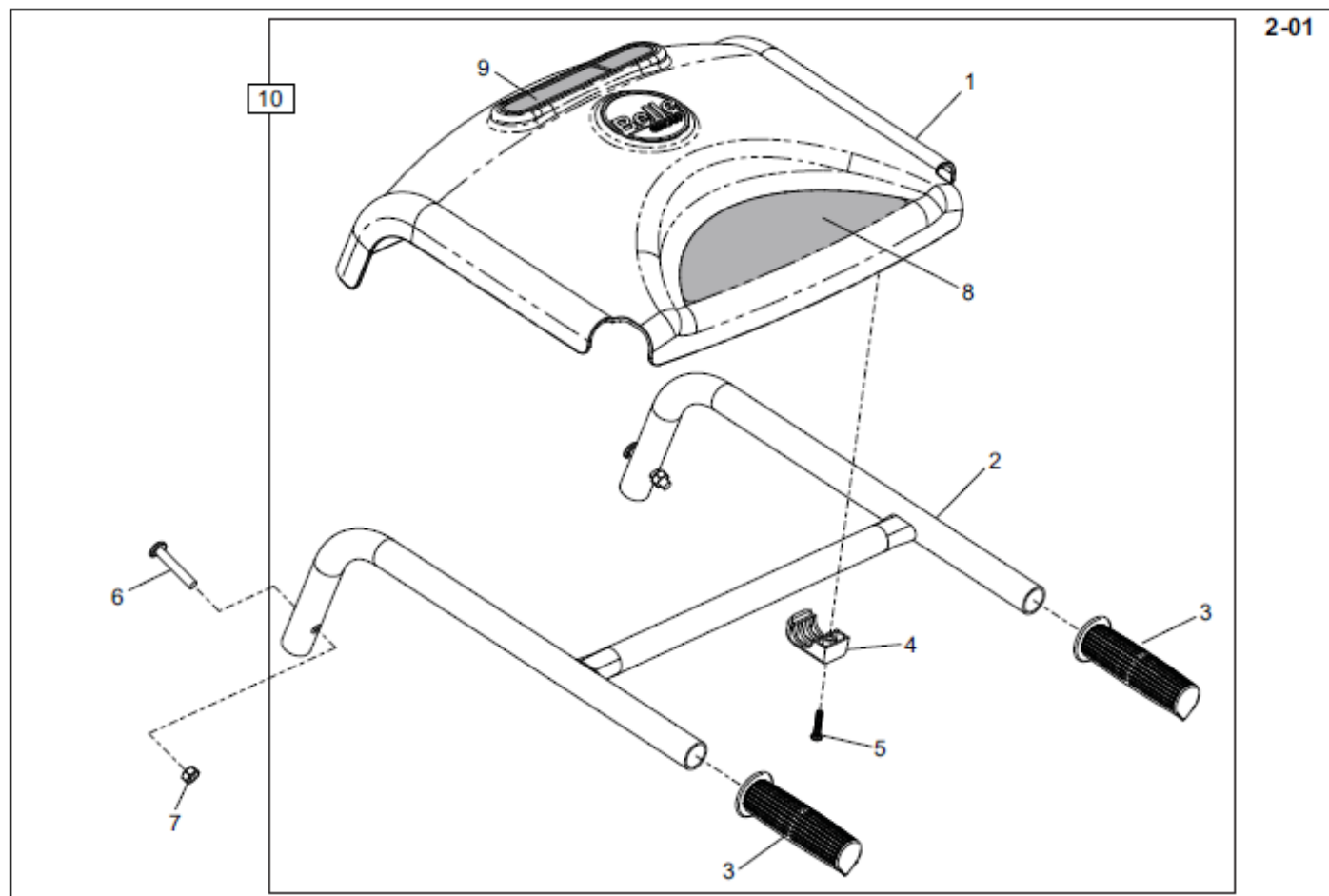

Handle Assembly, Ensemble Poignée, Conjunto de Manillar, Conjunto do Punho

2-01

1	900/99914	Cover - Orange	Couverde - Orange	Cubierta - Naranja	Tampa - Arancione	Minimix	1
1	900/99914G2	Cover - Green	Couverde - Vert	Cubierta - Verde	Tampa - Verde	Minimix	1
1	900/99914R	Cover - Red	Couverde - Rouge	Cubierta - Roja	Tampa - Vermelho	Minimix	1
1	900/99914GR2	Cover - Grey	Couverde - Gris	Cubierta - Gris	Tampa - Grey	Minimix	1
1	900/99930	Cover - Orange	Couverde - Orange	Cubierta - Naranja	Tampa - Arancione	Easymix	1
1	900/99930G2	Cover - Green	Couverde - Vert	Cubierta - Verde	Tampa - Verde	Easymix	1
1	900/99930R	Cover - Red	Couverde - Rouge	Cubierta - Roja	Tampa - Vermelho	Easymix	1
1	900/99930GR2	Cover - Grey	Couverde - Gris	Cubierta - Gris	Tampa - Grey	Easymix	1
2	900/25000	Handle - Orange	Poignée - Orange	Manillar - Naranja	Punho - Arancione	Honda / Electric	1
2	900/25000G2	Handle - Green	Poignée - Vert	Manillar - Verde	Punho - Verde	Honda / Electric	1
2	900/25000R	Handle - Red	Poignée - Rouge	Manillar - Roja	Punho - Vermelho	Honda / Electric	1
2	900/25000GR2	Handle - Grey	Poignée - Gris	Manillar - Grey	Punho - Gris	Honda / Electric	1
2	900/37800	Handle - Orange	Poignée - Orange	Manillar - Naranja	Punho - Arancione	Robin	1
2	900/37800G2	Handle - Green	Poignée - Vert	Manillar - Verde	Punho - Verde	Robin	1
2	900/37800R	Handle - Red	Poignée - Rouge	Manillar - Roja	Punho - Vermelho	Robin	1
2	900/37800GR2	Handle - Grey	Poignée - Gris	Manillar - Grey	Punho - Gris	Robin	1
3	XS35	Hand Grip	Poignée	Asas	Punhos		2
4	900/99918	Clamp - Orange	Serrage - Orange	Mordaza - Naranja	Grampo - Arancione		2
4	900/99918G2	Clamp - Green	Serrage - Vert	Mordaza - Verde	Grampo - Verde		2
4	900/99918R	Clamp - Red	Serrage - Rouge	Mordaza - Roja	Grampo - Vermelho		2
4	900/99918GR2	Clamp - Grey	Serrage - Gris	Mordaza - Grey	Grampo - Gris		2
5	7/5017	Screw	Vis	Tornillo	Parafuso	5.5 x 25	2
6	9/8021	Bolt	Boulon	Perno	Perno	M8	2
7	8/8001	Nut	Ecrou	Tuerca	Porca	M8	2
8	800/21300	Decal	Etiquette	Etiqueta	Etiqueta		1
10	900/31700	Handle Assy - Orange	Ens. Poignéé - Orange	Cjto de Manillar - Naranja	Cjto do Punho - Arancione	Honda / Electric	1
10	900/31700G2	Handle Assy - Green	Ens. Poignéé - Vert	Cjto de Manillar - Verde	Cjto do Punho - Verde	Honda / Electric	1
10	900/31700R	Handle Assy - Red	Ens. Poignéé - Rouge	Cjto de Manillar - Roja	Cjto do Punho - Vermelho	Honda / Electric	1
10	900/31700GR2	Handle Assy - Grey	Ens. Poignéé - Gris	Cjto de Manillar - Grey	Cjto do Punho - Gris	Honda / Electric	1

3-01

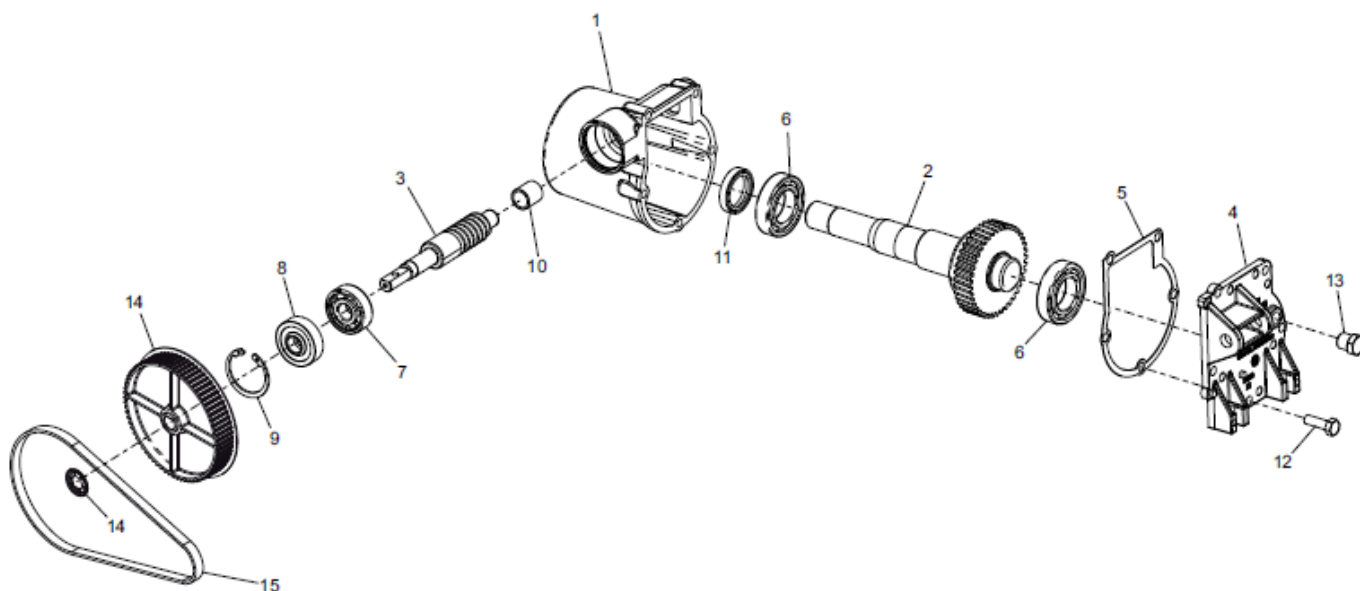

Gearbox Assembly (→ Jul '99 → Oct '04)

3-01

1	MS08Gearbox CaseCarter de boîte de vitessesEnvoltura de la transmisiónCaixa de engrenagens1
2	MS09Drum ShaftArbre de tambourEje de tamborVeio do Tambor1
3	900/24701Worm ShaftAxeEje HelicoidalVeio helicoidal1
4	MS10Back PlatePlaque ArrièrePlaca TraseraPlaca de Apoio1
5	MS11GasketJoint d'étanchéité à l'huileJuntaGaxeta1
6	CMS10BearingRoulementCojneteRolamento2
7	PS013BearingRoulementCojneteRolamento1
8	CMS41Oil SealJoint d'étanchéité à l'huileObturador aceiteVedante de Óleo1
9	MS22CirclipCirclipResorte circularGrampo circular1
10	MS13BushDouilleBujeBucha19 x 15 x 20
11	CMS11Oil SealJoint d'étanchéité à l'huileObturador aceiteVedante de Óleo1
12	7/8003ScrewVisTomilloParafusoM8 x 25
13	MS12BungObturatorTapónTampão1
14	900/30000Gearbox Pulley KitKit De Poulie De BoîteKit Polea ReductoraPolia reductora completa50Hz, G100, Robin, B & S
14	900/31600Gearbox Pulley KitKit De Poulie De BoîteKit Polea ReductoraPolia reductora completa60Hz, GXH50
15	900/99915BeltCourroieCorreaCorreia50Hz, G100, EY08, B & S
15	900/99926BeltCourroieCorreaCorreia60Hz, GXH50, EH09DU

3-02

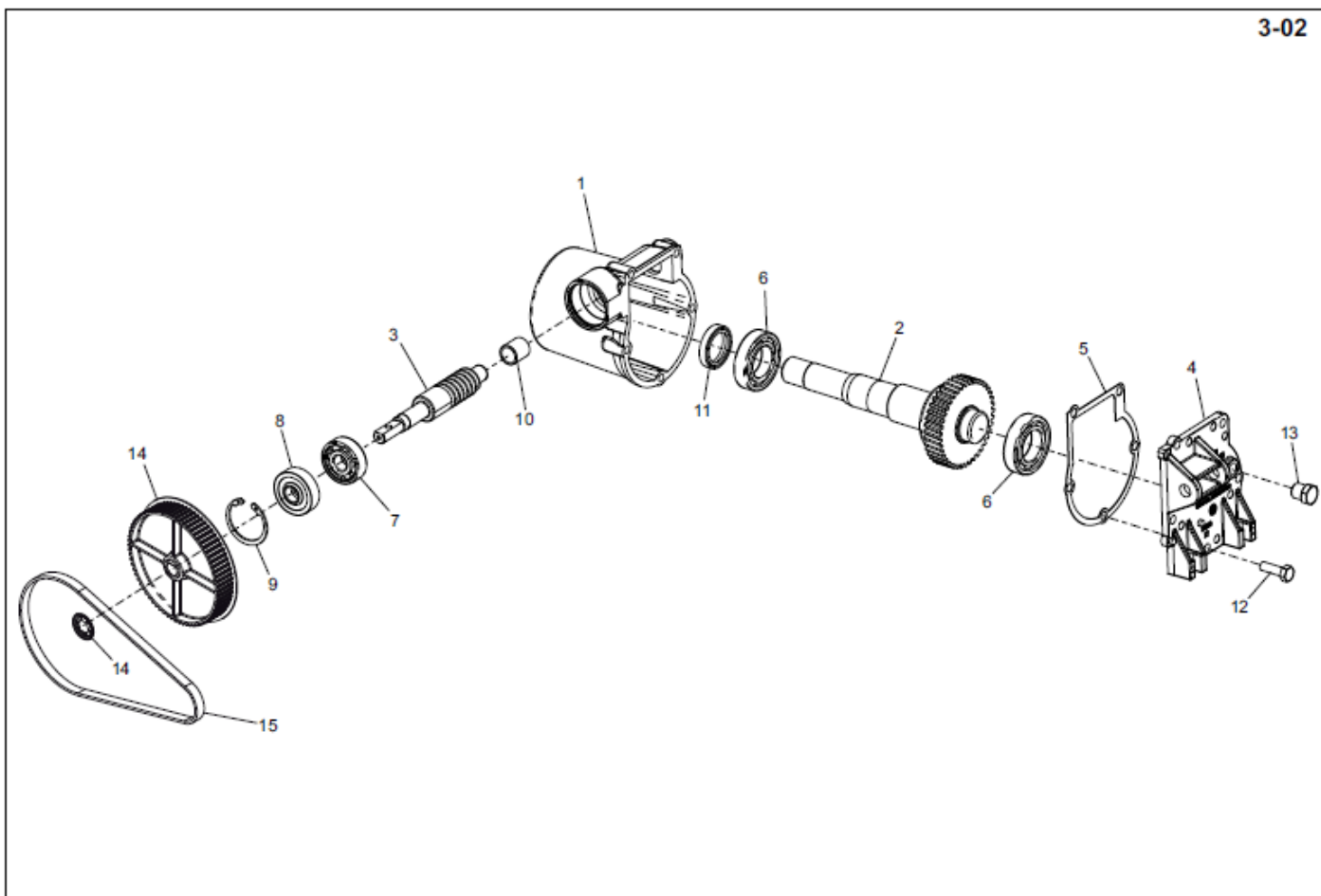

Gearbox Assembly (→ Oct '04)

3-02

1	900/37602Gearbox CaseCarter de boîte de vitessesEnvoladura de la transmisiónCaixa de engrenagens1
2	MS09Drum ShaftArbre de tambourEje de tamborVeio do Tambor1
3	900/37601Worm ShaftAxeEje HelicoidalVeio helicoidal1
4	MS10Back PlatePlaque ArrièrePlaca TraseraPlaca de Apoio1
5	MS11GasketJointJuntaJunta1
6	CMS10BearingRoulementCojineteRolamento2
7	53/0032BearingRoulementCojineteRolamento1
8	5/0052Oil SealJoint d'étanchéité à l'huileObturador aceiteVedante de Óleo1
9	MS22CirclipCirclipResorte circularGrampo circular1
10	MS13BushDouilleBujeBucha19 x 15 x 20.....1
11	CMS11Oil SealJoint d'étanchéité à l'huileObturador aceiteVedante de Óleo1
12	7/8003ScrewVisTomilloParafusoM8 x 25.....5
13	MS12BungObturateurTapónTampão1
14	900/30000Gearbox Pulley KitKit De Poulie De BoîteKit Polea ReductoraPolia reductora completa50Hz, G100, Robin, B & S ...1
14	900/31600Gearbox Pulley KitKit De Poulie De BoîteKit Polea ReductoraPolia reductora completa60Hz, GXH501
15	900/99915BeltCourroieCorreaCorreia50Hz, G100, EY08, B & S ...1
15	900/99926BeltCourroieCorreaCorreia60Hz, GXH50, EH09DU1

4-02

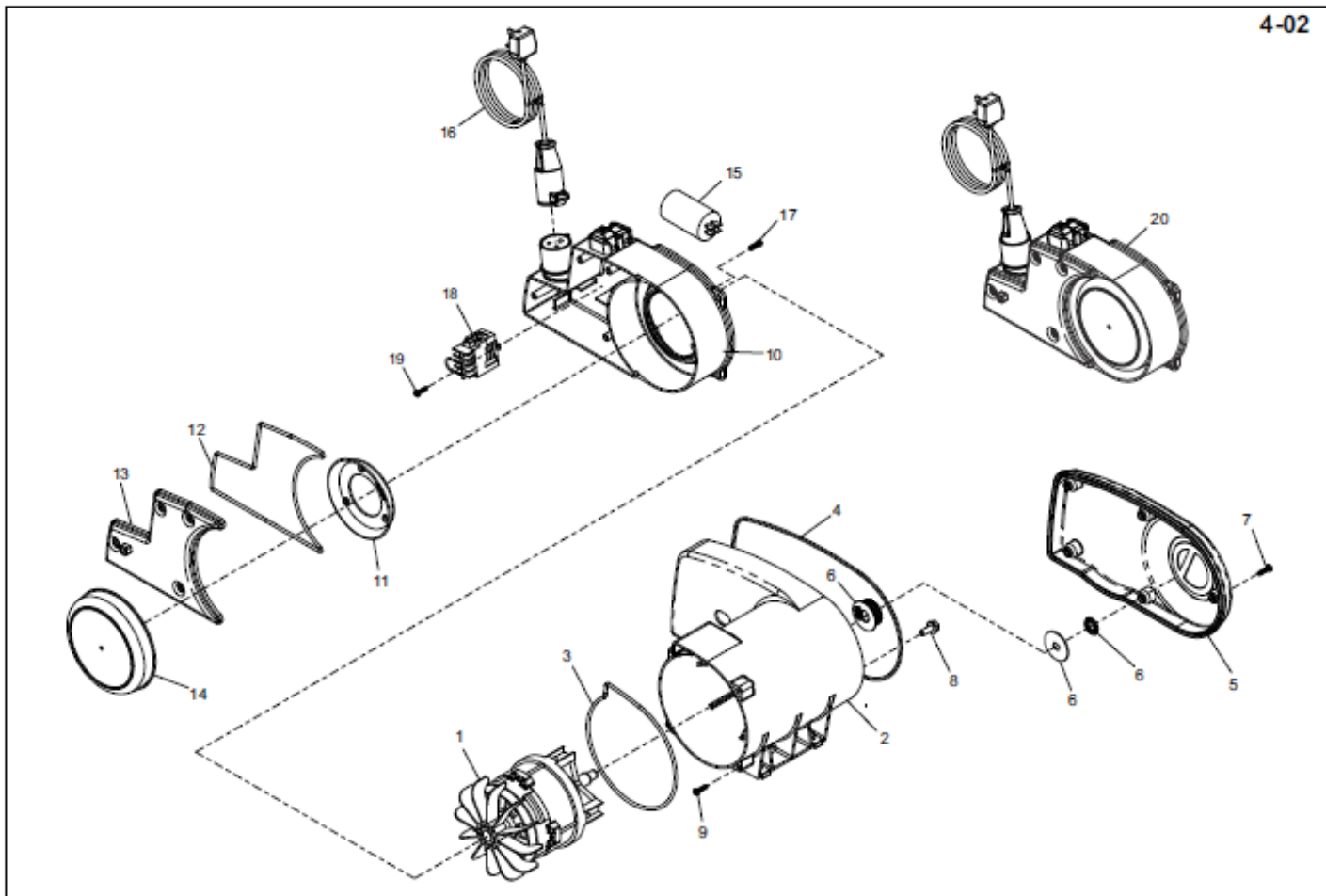

Motor Assembly (→Apr '02)

4-02

1	900/26800	Motor	Moteur	Motor	Motor	110v, 50Hz	1
1	900/22100	Motor	Moteur	Motor	Motor	230v, 50Hz	1
1	900/22400	Motor	Moteur	Motor	Motor	415v, 50Hz	1
2	900/41201	Motor Housing	Bloc Moteur	Tapa Motor	Cárter do Motor		1
3	900/99908	Seal	Joint d'étanchéité	Obturador	Vedante		1
4	900/99907	Seal	Joint d'étanchéité	Obturador	Vedante		1
5	900/26103	Belt Guard	Capot de courroie	Protector de la correa	Guarda da Correia		1
6	900/29900	Electric Pulley Kit	Kit Poulie De Moteur Electrique	Kit Polea Electrica	Polia eléctrica completa		1
7	7/5017	Screw	Vis	Tornillo	Parafuso	5.5 x 25	5
8	7/8037	Screw	Vis	Tornillo	Parafuso	M8 x 20	4
9	7/5016	Screw	Vis	Tornillo	Parafuso	5.5 x 16	4
10	900/26102	Switch Housing	Logement De L'interrupteur	Tapa Interruptor	Tampa do Interruptor		1
10	900/28901	Switch Housing	Logement De L'interrupteur	Tapa Interruptor	Tampa do Interruptor	Glanded Cable	1
11	901/99915	Cover	Couvercle	Cubierta	Tampa		1
12	900/99909	Seal	Joint d'étanchéité	Obturador	Vedante		1
13	900/26104	Cover	Couvercle	Cubierta	Tampa		1
14	901/99916	Cover	Couvercle	Cubierta	Tampa		1
15	70/0135	Capacitor	Condensateur	Condensador	Condensador	25 UF	1
15	70/0136	Capacitor	Condensateur	Condensador	Condensador	110UF	1
16	900/18100	Extension Cable	Câble De Prolongation	Extensión Cable	Cabo de extensão		1
17	7/0008	Screw	Vis	Tornillo	Parafuso	M4 x 19	3
18	901/99921	On /Off Switch	Commutateur Marche / Arrêt	Conmutador On/Off	Interruptor Ligado / Desligado	230v, 50Hz	1
18	901/99923	On /Off Switch	Commutateur Marche / Arrêt	Conmutador On/Off	Interruptor Ligado / Desligado	110v, 50Hz	1
18	900/99929	On /Off Switch	Commutateur Marche / Arrêt	Conmutador On/Off	Interruptor Ligado / Desligado	415v, 50Hz	1
19	7/0009	Screw	Vis	Tornillo	Parafuso	3.5 x 9.5	2
20	900/28700	Switch Assembly	Interrupteur Complet	Ensamblaje Interruptor	Conjunto do Interruptor	110v, 50Hz	1
20	900/29300	Switch Assembly	Interrupteur Complet	Ensamblaje Interruptor	Conjunto do Interruptor	230v, 50Hz, UK	1
20	900/29000	Switch Assembly	Interrupteur Complet	Ensamblaje Interruptor	Conjunto do Interruptor	415v, 50Hz	1

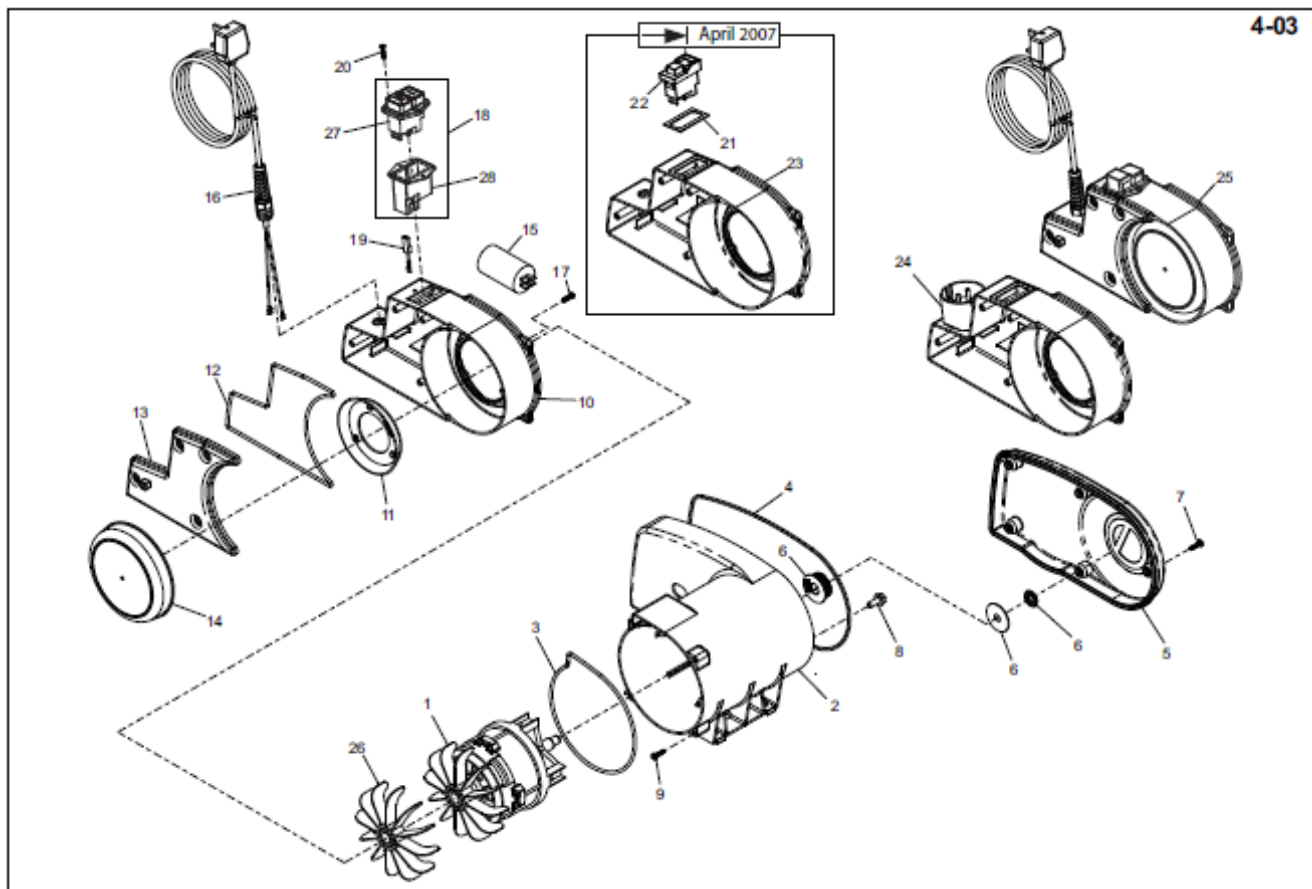

Motor Assembly (→ Apr '02) 4-03

1	900/34400	Motor	Moteur	Motor	Motor	110v, 50Hz	1	
1	900/34300	Motor	Moteur	Motor	Motor	230v, 50Hz	1	
1	900/22400	Motor	Moteur	Motor	Motor	415v, 50Hz	1	
2	900/41201	Motor Housing	Bloc Moteur	Tapa Motor	Motor	Cárter do Motor	1	
3	900/99908	Seal	Joint d'étanchéité	Obturador	Obturador	Vedante	1	
4	900/99907	Seal	Joint d'étanchéité	Obturador	Obturador	Vedante	1	
5	900/26103	Belt Guard	Capot de courroie	Protector de la correa	Protector de la correa	Guarda da Correia	1	
6	900/29900	Electric Pulley Kit	Kit Poulie De Moteur Electrique	Kit Polea Electrica	Kit Polea Electrica	Polla eléctrica completa	1	
7	7/5017	Screw	Vis	Tornillo	Parafuso	5.5 x 25	5	
8	7/8037	Screw	Vis	Tornillo	Parafuso	M8 x 20	4	
9	7/5016	Screw	Vis	Tornillo	Parafuso	5.5 x 16	4	
10	900/33801	Switch Housing	Logement De L'Interrupteur	Tapa Interruptor	Tapa Interruptor	Glanded	1	
11	901/99915	Cover	Couverde	Cubierta	Cubierta	Tampa	1	
12	900/99909	Seal	Joint d'étanchéité	Obturador	Obturador	Vedante	1	
13	900/26104	Cover	Couverde	Cubierta	Cubierta	Tampa	1	
14	901/99916	Cover	Couverde	Cubierta	Cubierta	Tampa	1	
15	70/0135	Capacitor	Condensateur	Condensador	Condensador	25UF	1	
15	70/0136	Capacitor	Condensateur	Condensador	Condensador	110UF	1	
16	71/0180	Cable Assembly	Faisceau De Câbles	Ensamblaje Cable	Ensamblaje Cable	Conjunto do Cabo	110v, 50Hz	1
16	71/0179	Cable Assembly	Faisceau De Câbles	Ensamblaje Cable	Ensamblaje Cable	Conjunto do Cabo	230v, 50Hz, UK	1
17	7/0008	Screw	Vis	Tornillo	Parafuso	M4 x 19	3	
18	900/41700	Switch Kit	Interrupteur Complet	Ensamblaje Interruptor	Ensamblaje Interruptor	Conjunto de Interruptor	230v, 50Hz	1
18	900/41800	Switch Kit	Interrupteur Complet	Ensamblaje Interruptor	Ensamblaje Interruptor	Conjunto de Interruptor	110v, 50Hz	1
19	71/0258	Wire	Câble	Cable	Cable	Cabo	1	
20	7/4009	Screw	Vis	Tornillo	Parafuso	Dia. 4	2	
21	70/0195	Seal	Joint d'étanchéité	Obturador	Obturador	Vedante	1	
22	70/0194	On /Off Switch	Commutateur Marche / Arrêt	Commutador On/Off	Commutador On/Off	Interruptor Ligado / Desligado	230v, 50Hz	1
22	70-0202	On /Off Switch	Commutateur Marche / Arrêt	Commutador On/Off	Commutador On/Off	Interruptor Ligado / Desligado	110v, 50Hz	1
23	25	Switch Housing	Logement De L'Interrupteur	Tapa Interruptor	Tapa Interruptor	Tampa do Interruptor	1	
24	25	Switch Housing	Logement De L'Interrupteur	Tapa Interruptor	Tapa Interruptor	Tampa do Interruptor	1	
25	900/34500	Switch Assembly	Interrupteur Complet	Ensamblaje Interruptor	Ensamblaje Interruptor	Conjunto do Interruptor	110v, 50Hz	1
25	900/33800	Switch Assembly	Interrupteur Complet	Ensamblaje Interruptor	Ensamblaje Interruptor	Conjunto do Interruptor	230v, 50Hz, UK	1
25	900/29000	Switch Assembly	Interrupteur Complet	Ensamblaje Interruptor	Ensamblaje Interruptor	Conjunto do Interruptor	415v, 50Hz	1
26	900/99946	Fan	Ventilateur	Ventilador	Ventilador	Ventilador	110v & 230v	1
27	70/0247	On /Off Switch	Commutateur Marche / Arrêt	Commutador On/Off	Commutador On/Off	Interruptor Ligado / Desligado	230v, 50Hz	1
27	70/0252	On /Off Switch	Commutateur Marche / Arrêt	Commutador On/Off	Commutador On/Off	Interruptor Ligado / Desligado	110v, 50Hz	1
28	70/0249	Cover	Couverde	Cubierta	Cubierta	Tampa	1	

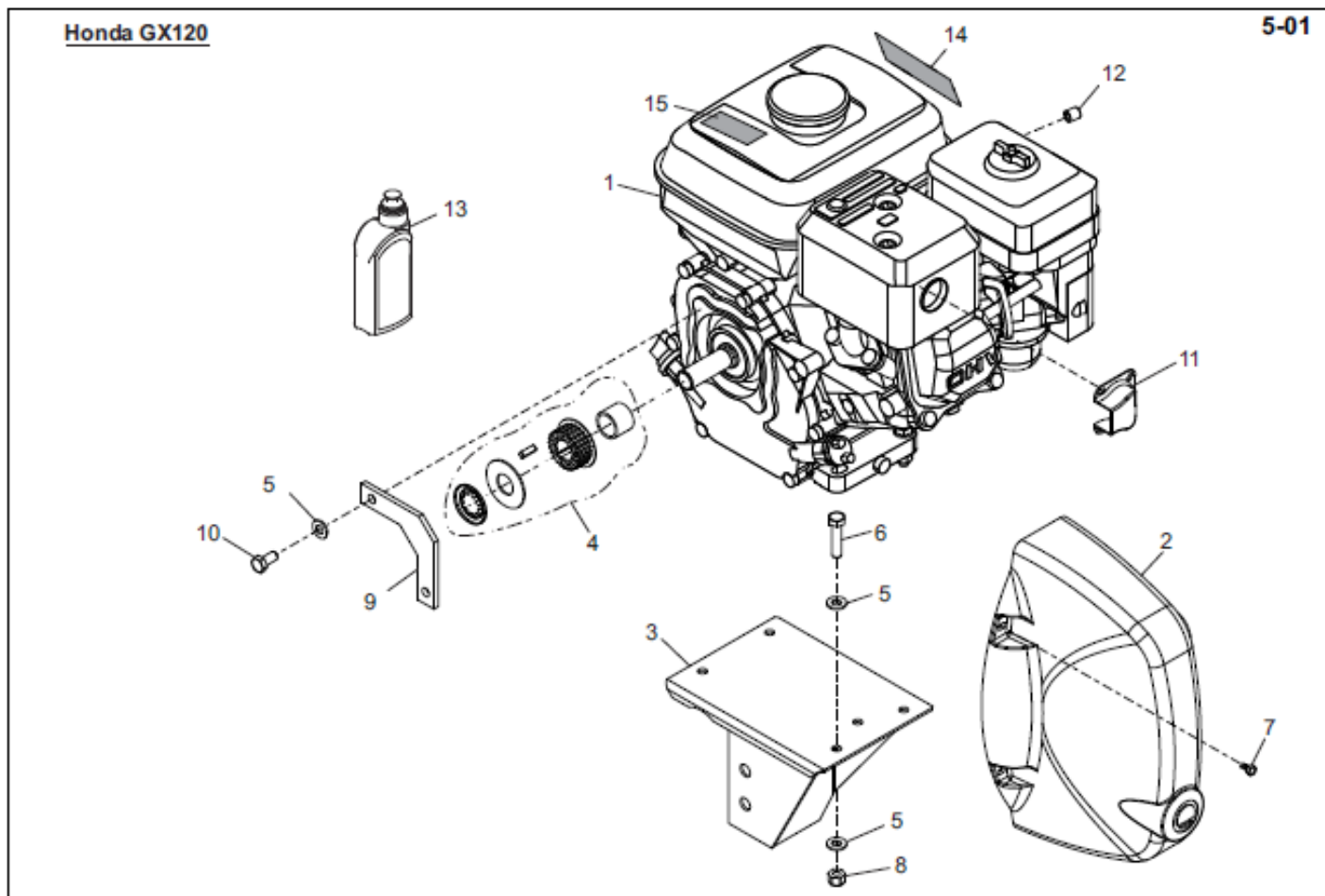

Engine Assembly (Honda GX120)

5-01

1	20/0038	Engine	Moteur	Motor	Motor	Honda GX120	1
2	900/99927	Belt Guard	Capot de courroie	Protector de la correa	Guarda da Correia		1
3	900/40400	Engine Deck - Orange	Support du Moteur - Orange	Cubierta Motor - Naranja	Suporte do Motor - Arancione		1
3	900/40400G2	Engine Deck - Green	Support du Moteur - Vert	Cubierta Motor - Verde	Suporte do Motor - Verde		1
3	900/40400R	Engine Deck - Red	Support du Moteur - Rouge	Cubierta Motor - Roja	Suporte do Motor - Vermelho		1
3	900/40400GR2	Engine Deck - Grey	Support du Moteur - Gris	Cubierta Motor - Grey	Suporte do Motor - Gris		1
4	900/31000	Engine Pulley Kit	Kit De Poulie De Moteur	Kit Polea Motor	Polia completa do motor		1
5	4/8006	Washer	Rondelle	Arandela	Anilha		10
6	9/8003	Screw	Vis	Tornillo	Parafuso	M8 x 35	4
7	7/10002	Screw	Vis	Tornillo	Parafuso	10 x 3/8"	2
8	8/8008	Nut	Ecrou	Tuerca	Porca	M8	4
9	900/99944	Bracket - Orange	Patte de montage - Orange	Escuadra - Naranja	Suporte - Arancione		1
9	900/99944G2	Bracket - Green	Patte de montage - Verde	Escuadra - Verde	Suporte - Verde		1
9	900/99944R	Bracket - Red	Patte de montage - Rouge	Escuadra - Roja	Suporte - Vermelho		1
9	900/99944GR2	Bracket - Grey	Patte de montage - Gris	Escuadra - Grey	Suporte - Gris		1
10	9/0002	Screw	Vis	Tornillo	Parafuso	5/16" x 5/8"	2
11	21/0236	Exhaust Deflector	Protection D'échappement	Protector Escape	Proteção de Escape		1
12	900/99945	Boss	Vis	Tornillo	Parafuso	M6 x 16	1
13	92/00002	Engine Oil	Huile Moteur	Acelle Motor	Óleo do Motor	750ml	
14	800/99743	Decal	Etiquette	Etiqueta	Etiqueta	Emergency Stop	1
15	800/21320	Decal	Etiquette	Etiqueta	Etiqueta	Hot Parts	1

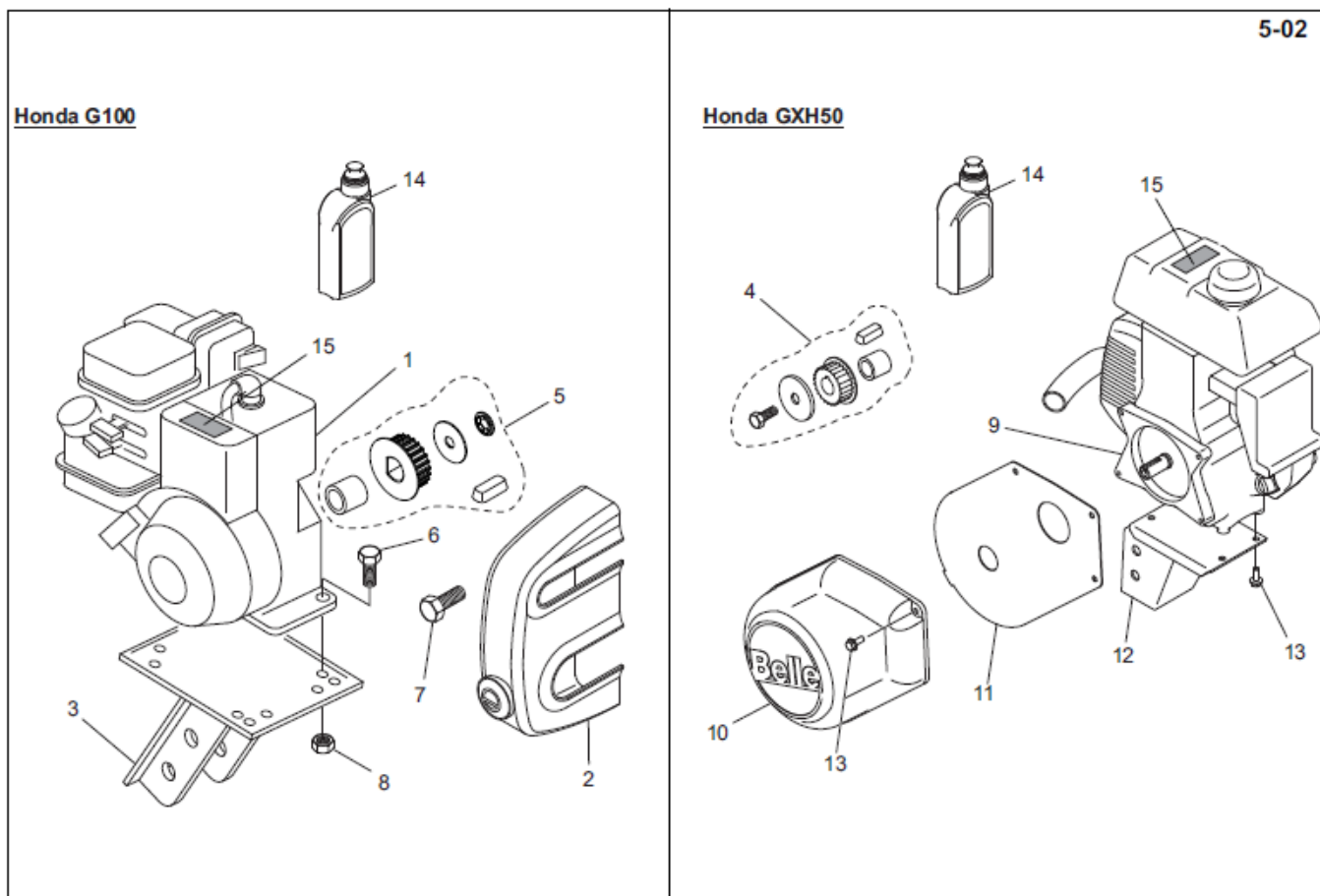

Engine Assembly (Honda)

5-02

1	MS15.....	Engine.....	Moteur.....	Motor.....	Motor.....	Honda G100.....	1
2	900/99927.....	Belt Guard.....	Capot de courroie.....	Protector de la correa.....	Guarda da Correia.....		1
3	900/33200.....	Engine Deck.....	Plate-Forme De Moteur.....	Cubierta Motor.....	Suporte do Motor.....		1
4	900/36400.....	Engine Pulley Kit.....	Kit De Poulie De Moteur.....	Kit Polea Motor.....	Polia completa do motor.....		1
5	900/32600.....	Engine Pulley Kit.....	Kit De Poulie De Moteur.....	Kit Polea Motor.....	Polia completa do motor.....		1
6	7/8008.....	Screw.....	Vis.....	Tomillo.....	Parafuso.....	M8 x 16.....	4
7	7/10002.....	Screw.....	Vis.....	Tomillo.....	Parafuso.....	10 x 3/8".....	2
8	8/8001.....	Nut.....	Ecrou.....	Tuerca.....	Porca.....	M8.....	4
9	20/0031.....	Engine.....	Moteur.....	Motor.....	Motor.....	Honda GXH50.....	1
10	900/99935.....	Belt Guard.....	Capot de courroie.....	Protector de la correa.....	Guarda da Correia.....		1
11	900/99934.....	Plate.....	Plaque.....	Placa.....	Placa.....		1
12	900/35300.....	Engine Deck.....	Plate-Forme De Moteur.....	Cubierta Motor.....	Suporte do Motor.....		1
13	7/6034.....	Screw.....	Vis.....	Tomillo.....	Parafuso.....	M6 x 16.....	4
14	92/00002.....	Engine Oil.....	Huile Moteur.....	Aceite Motor.....	Óleo do Motor.....	750ml	
15	800/21320.....	Decal.....	Etiquette.....	Etiqueta.....	Etiqueta.....	Hot Parts.....	1

5-03

Robin EY08

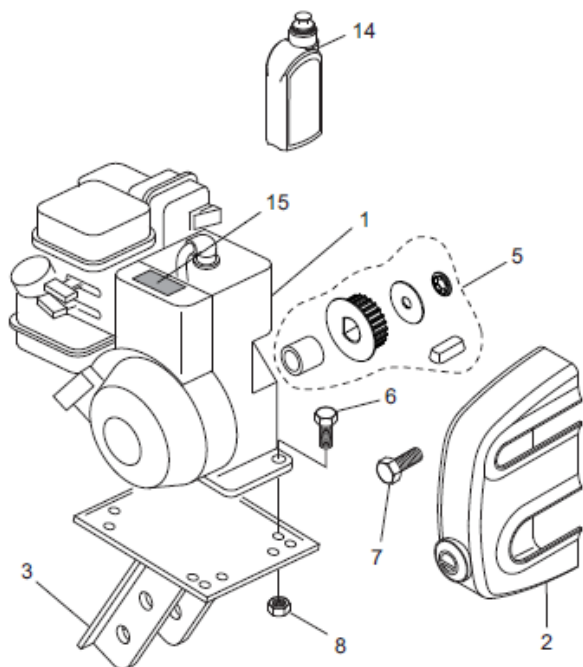

Robin EH09DU

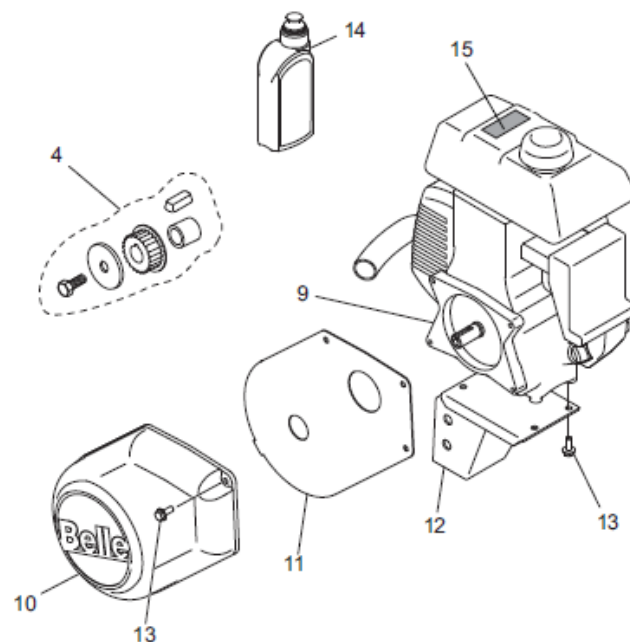

Engine Assembly (Robin)

5-03

1	MS16.....	Engine	Moteur	Motor.....	Motor	Motor	Robin EY08	1
2	900/99927	Belt Guard	Capot de courroie	Protector de la correa.....	Guarda da Correia	Guarda da Correia	Robin EY08	1
3	900/33300	Engine Deck.....	Plate-Forme De Moteur	Cubierta Motor	Suporte do Motor	Suporte do Motor	Robin EY08	1
4	900/38400	Engine Pulley Kit.....	Kit De Poulie De Moteur	Kit Polea Motor.....	Polia completa do motor.....	Polia completa do motor.....	Robin EY08	1
5	900/32600	Engine Pulley Kit.....	Kit De Poulie De Moteur	Kit Polea Motor.....	Polia completa do motor.....	Polia completa do motor.....	Robin EY08	1
6	9/8003	Screw	Vis	Tomillo	Parafuso	Parafuso	M8 x 35	4
7	7/10002	Screw	Vis	Tomillo	Parafuso	Parafuso	10 x 3/8"	2
8	8/8001	Nut	Ecrou.....	Tuerca	Porca	Porca	M8	4
9	20/0060	Engine	Moteur	Motor.....	Motor	Motor	Robin EH09DU	1
10	900/99935	Belt Guard	Capot de courroie	Protector de la correa.....	Guarda da Correia	Guarda da Correia	Robin EH09DU	1
11	900/37900	Plate - Orange	Plaque - Orange.....	Placa - Orange	Placa - Arancione	Placa - Arancione	Robin EH09DU	1
11	900/37900G2	Plate - Green.....	Plaque - Verde.....	Placa - Verde	Placa - Verde	Placa - Verde	Robin EH09DU	1
11	900/37900R.....	Plate - Red.....	Plaque - Rouge	Placa - Orange	Placa - Arancione	Placa - Arancione	Robin EH09DU	1
11	900/37900GR2	Plate - Grey	Plaque - Gris	Placa - Grey	Placa - Gris.....	Placa - Gris.....	Robin EH09DU	1
12	900/38000	Engine Deck - Orange	Plate-Forme De Moteur - Orange.....	Cubierta Motor - Naranja.....	Suporte do Motor - Arancione	Suporte do Motor - Arancione	Robin EH09DU	1
12	900/38000G2	Engine Deck - Green	Plate-Forme De Moteur - Vert.....	Cubierta Motor - Verde.....	Suporte do Motor - Verde	Suporte do Motor - Verde	Robin EH09DU	1
12	900/38000R.....	Engine Deck - Red.....	Plate-Forme De Moteur - Rouge.....	Cubierta Motor - Roja.....	Suporte do Motor - Vermelho.....	Suporte do Motor - Vermelho.....	Robin EH09DU	1
12	900/38000GR2	Engine Deck - Grey.....	Plate-Forme De Moteur - Gris.....	Cubierta Motor - Grey	Suporte do Motor - Gris.....	Suporte do Motor - Gris.....	Robin EH09DU	1
13	7/6034	Screw	Vis	Tomillo	Parafuso	Parafuso	M6 x 16	4
14	92/00002	Engine Oil	Huile Moteur	Aceite Motor	Aceite Motor	Aceite Motor	450ml	1
15	800/21320	Decal	Étiquette	Etiqueta	Etiqueta	Etiqueta	Hot Parts	1



No.1 for Light Construction Equipment

Belle Group Head Office

Sheen, Nr. Buxton
Derbyshire.
SK17 0EU
GB.
Tel: +44 (0)1298 84606
Fax: +44 (0)1298 84722
email: sales@belle-group.co.uk

Belle France SARL

1 rue de l'Equerre
ZI de Béthunes
BP 20541
95005 Cergy Pontoise Cedex
FRANCE
Tel: +33 (0) 1 34 21 45 83
Tel: +33 (0) 1 34 21 45 84
Fax: +33 (0) 1 30 37 31 28

Belle Equipos SL

Calle Doctor Calero Cial 19,
Local 22, 28220 Majadahonda
Madrid, Spain
Tel: +34 (0) 91 636 2043
Fax: +34 (0) 91 634 1535
email: belleequipos@belleequipos.com

Belle Group Deutschland

Husumer Straße 45 a,
D-33729,
Bielefeld
Deutschland
Tel : +49(0) 5217 707505
Fax : +49 (0) 5217 707506
Sales: 0800 1808069
Spares: 0800 1816673

Belle Poland sp. z.o.o.

96-200 Rawa Mazowiecka
Ul. Mszczonowska 36,
Polska
Tel: +48 (0) 46 8144091
Fax: +48 (0) 46 8144700

Belle Group Portugal

Rua Laura Alves, 225, 2º F
2775-116 Parede
Portugal
Tel: +35 1 (21) 453 59 91
Fax: +35 1 (21) 453 59 91

Belle Group Netherlands

Tel: 0800 249861

Belle Group Belgium

Tel: 0800 80295

Belle Group Austria

Tel: 0800 291544

Belle Group Russia

64 Nevsky pr.
St. Petersburg
Russia
Tel : +7(812)314-81-34
Moscow : +7(495)589-64-32

Belle Group South East Asia

21, Jalan Ara AD 7/3B,
Pandara Sri Damansara
S2200 Kuala Lumpur, Malaysia
Tel: +60 (0) 3 62721678
+60 (0) 3 6272 9308
Fax: +60 (0) 3 6272 9528

Belle Group (GB), Shanghai Office

Room 213, Zhonghuang Building,
1007 Zhongshan Nan Er Road,
Xuhui, Shanghai 200030 China
Tel: 00 - 86 - 21 - 5461 5228
Mobile: 00 - 86 - 133 8172 2653
Fax: 00 - 86 - 21 - 5461 5369
email: morgan.liu@bellegroup.com.cn

Belle Group Inc

3959 Electric Rd
Roanoke
Suite 360
VA 24018. USA.
Tel: +1.540.345.5090
Fax: +1.540.345.5091
Toll free 866 540 5090
e-mail: sales@bellegroup.net



Belle Group World Parts Centre

Sheen, Nr. Buxton
Derbyshire.
SK17 0EU
GB.
Tel: +44 (0)1298 84606
Fax: +44 (0)1298 84722
email: parts@belle-group.co.uk

www.Altrad.com

www.BelleGroup.com



COMPACTING...



MIXING...



CONCRETING...



CUTTING...



BREAKING...



MOVING