

Makita Wall Chaser SG1250

Designed for cutting channels into vertical surfaces for the running of cables and pipes. Fitted with a powerful 1400W motor and Makita's SJS system making the machine user friendly.

User Benefits

- Can be used with single or twin diamond blades
- Front cover efficiently prevents dust from spreading at every cutting depth
- Super joint system – avoids shock on accidental wheel jam
- Variable speed & anti vibration system



Machine Specifications

Wheel Diameter	125 mm
Cutting Depth	0 – 30 mm
No Load Speed	10,000 rpm
Overall Length	346 mm
Sound Pressure Level	98 dB(A)
Sound Power Level	111 dB(A)
Net Weight	4.1 kg

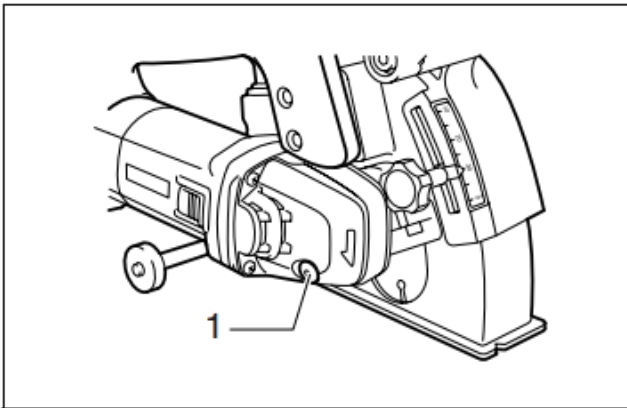

1

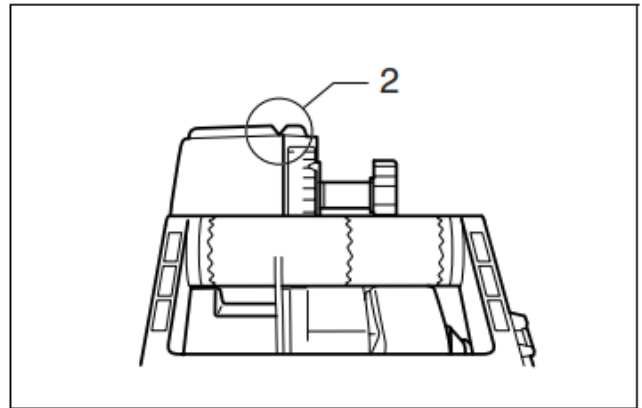

2

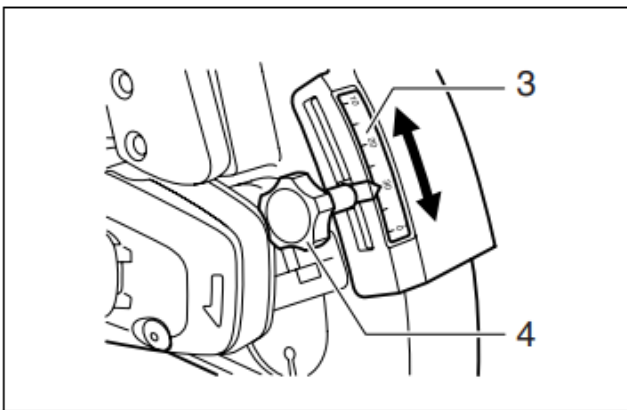

3

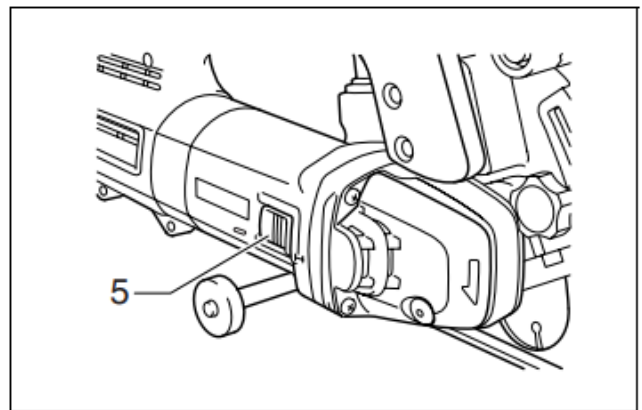

4

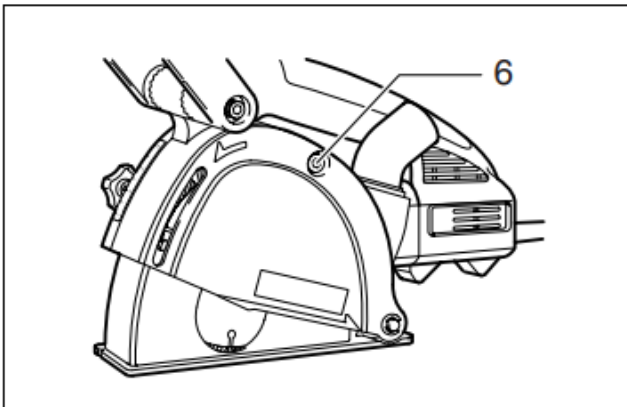

5

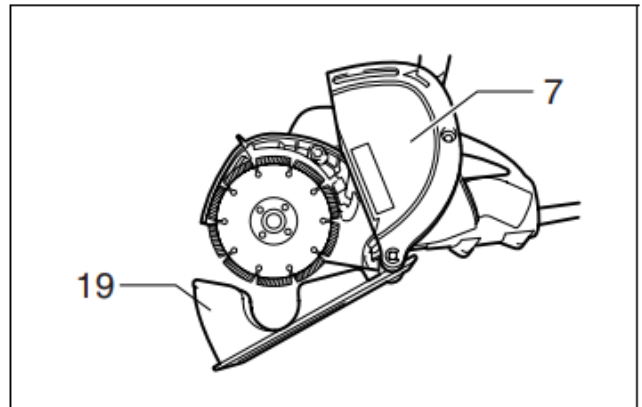

6

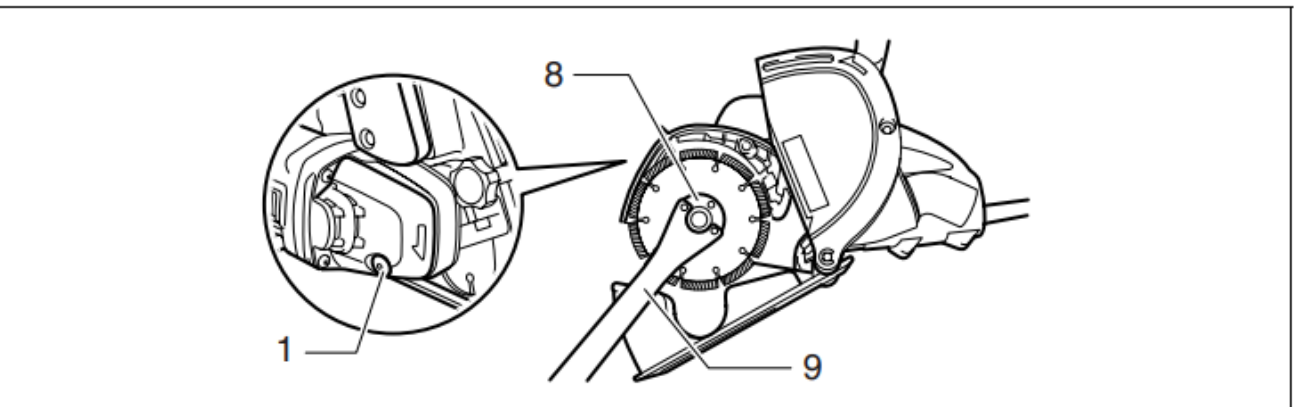

7

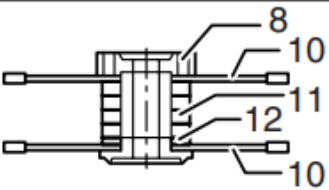
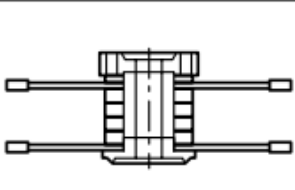
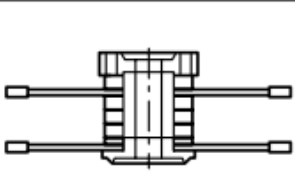
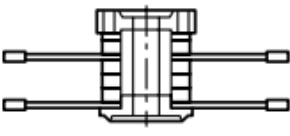
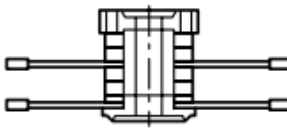
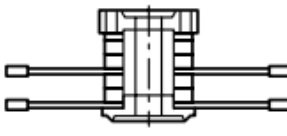
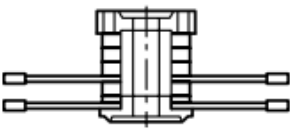
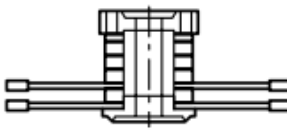
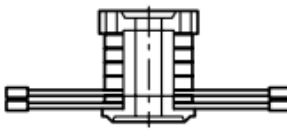
Groove width: 30 mm	Groove width: 27 mm	Groove width: 24 mm
		
Groove width: 21 mm	Groove width: 18 mm	Groove width: 15 mm
		
Groove width: 12 mm	Groove width: 9 mm	Groove width: 6 mm
		

8

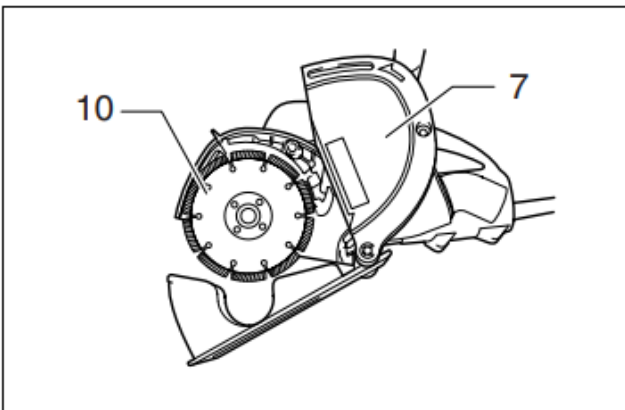

9

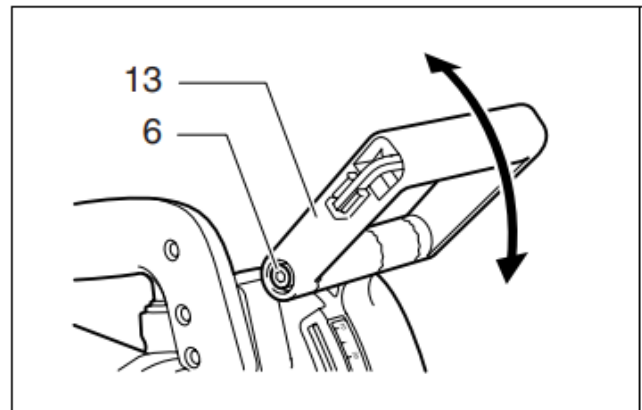

10

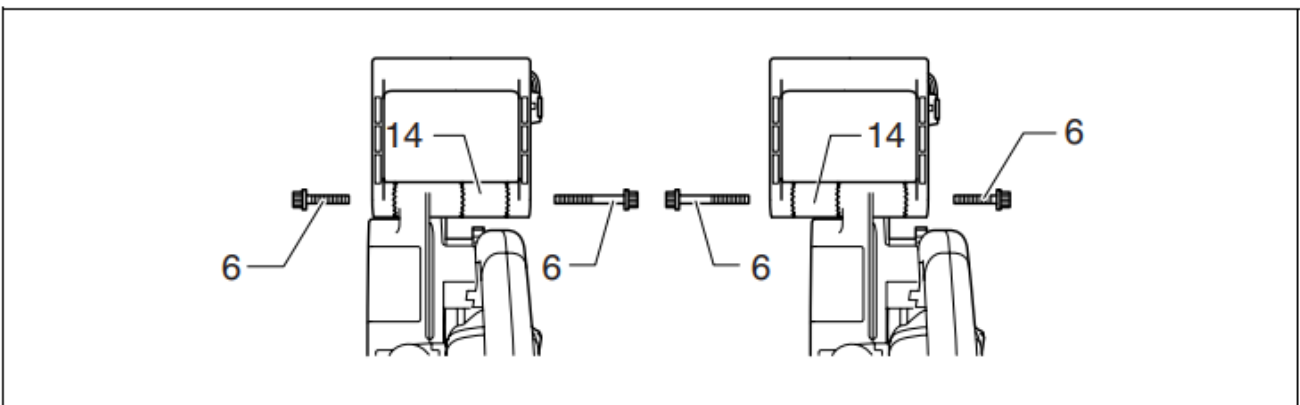

11

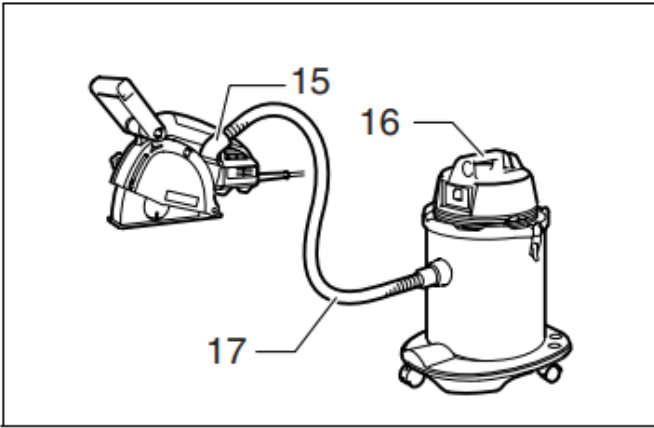

12

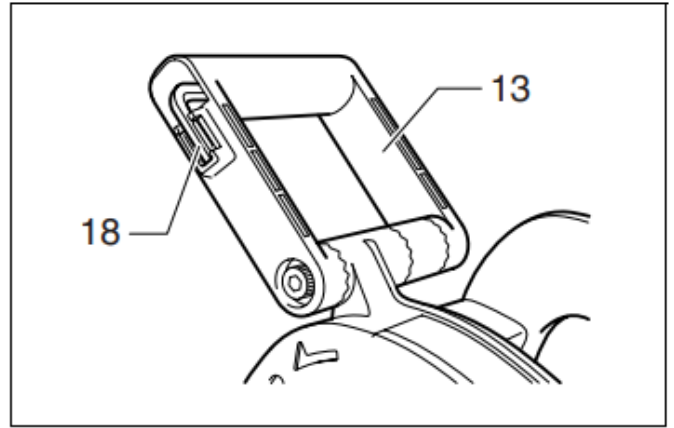

13

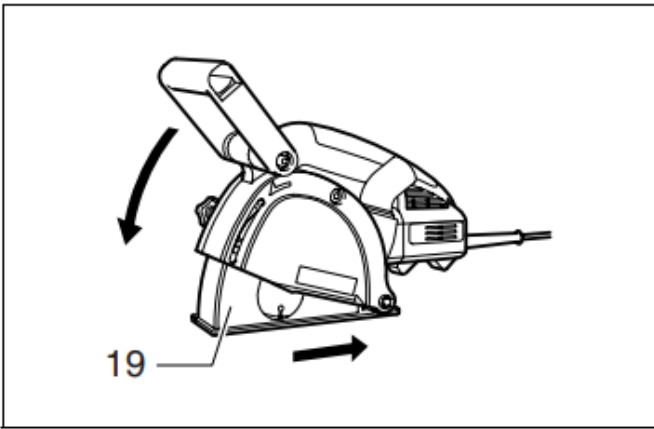

14

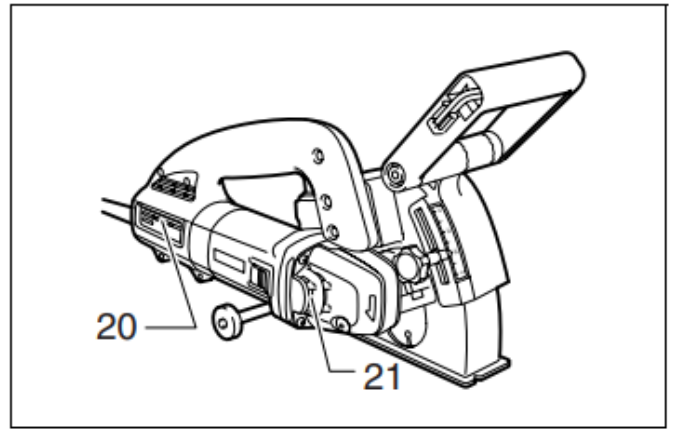

15

Symbols

The followings show the symbols used for the tool. Be sure that you understand their meaning before use.



Read instruction manual.



DOUBLE INSULATION



Wear safety glasses.

ENGLISH

Explanation of general view

1	Shaft lock	9	Lock nut wrench	17	Hose
2	Notch	10	Diamond wheel	18	Hex wrench
3	Scale	11	Space ring 6 (6 mm thick)	19	Base
4	Clamping screw	12	Space ring 3 (3 mm thick)	20	Inhalation vent
5	Switch lever	13	Front handle	21	Exhaust vent
6	Hex socket head bolt	14	Cam		
7	Cover	15	Dust nozzle		
8	Lock nut	16	Vacuum cleaner		

Intended use

The tool is intended for cutting tracks in concrete walls or cutting in ferrous materials or concrete drainage channels with a diamond wheel but without using water.

Power supply

The tool should be connected only to a power supply of the same voltage as indicated on the nameplate, and can only be operated on single-phase AC supply. They are double-insulated in accordance with European Standard and can, therefore, also be used from sockets without earth wire.

Safety hints

For your own safety, please refer to the enclosed safety instructions.

ADDITIONAL SAFETY RULES

ENB085-1

1. Always use eye and ear protection. Other personal protective equipment such as dust mask, gloves, helmet and apron should be worn.
2. Hold tool by insulated gripping surfaces when performing an operation where the cutting tool may contact hidden wiring or its own cord. Contact with a "live" wire will make exposed metal parts of the tool "live" and shock the operator.
3. Keep guards in place.
4. Use only wheels with the correct size and wheels having a maximum operating speed at least as high as the highest No Load Speed marked on the tool's nameplate.

5. Observe the instructions of the manufacturer for correct mounting.
6. Check that the workpiece is properly supported.
7. Pay attention that the wheel continues to rotate after the tool is switched off.
8. Ensure that the ventilation openings are kept clear when working in dusty conditions. If it should become necessary to clear dust, first disconnect the tool from the mains supply (use non metallic objects) and avoid damaging internal parts.
9. Watch out for flying sparks. Hold the tool so that sparks fly away from you and other persons or flammable materials.
10. Check the wheel carefully for cracks or damage before operation. Replace cracked or damaged wheel immediately.
11. Use only flanges specified for this tool.
12. Be careful not to damage the spindle, flanges (especially the installing surface) or bolt. Damage to these parts could result in wheel breakage.
13. Hold the tool firmly.
14. Keep hands away from rotating parts.
15. Make sure the wheel is not contacting the workpiece before the switch is turned on.
16. Wait until the wheel attains full speed before cutting.
17. Stop operation immediately if you notice anything abnormal.
18. Never attempt to cut with the tool held upside down in a vise. This can lead to serious accidents, because it is extremely dangerous.
19. Before setting the tool down after completing a cut, be sure that the wheel has come to a complete stop.
20. Do not stop the wheel by lateral pressure on the disc.
21. The tool must be used only for dry cutting. Do not use water.

SAVE THESE INSTRUCTIONS.

FUNCTIONAL DESCRIPTION

CAUTION:

- Always be sure that the tool is switched off and unplugged before adjusting or checking function on the tool.

Shaft lock (Fig. 1)

CAUTION:

- Never actuate the shaft lock when the spindle is moving. The tool may be damaged.

Press the shaft lock to prevent spindle rotation when installing or removing accessories.

Sighting (Fig. 2)

There are notches on the front and rear of the base. This is helpful for an operator to follow a straight cutting line.

Adjusting the grooving or cutting depth (Fig. 3)

The depth of grooving or cutting can be adjusted in the range of 0 through 30 mm.

Loosen and move the clamping screw so that the pointer points to your desired depth graduation on the scale.

Then tighten the clamping screw firmly.

Switch action (Fig. 4)

CAUTION:

- Before plugging in the tool, always check to see that the slide switch actuates properly and returns to the "OFF" position when the rear of the slide switch is depressed.

To start the tool, slide the slide switch toward the "I (ON)" position. For continuous operation, press the front of the slide switch to lock it.

To stop the tool, press the rear of the slide switch, then slide it toward the "O (OFF)" position.

Electronic function

The tools equipped with electronic function are easy to operate because of the following features.

Constant speed control

Electronic speed control for obtaining constant speed. Possible to get fine finish, because the rotating speed is kept constant even under load condition.

Soft start

Soft-start feature minimizes start-up shock, and makes the tool start smoothly.

Overload protector

When the tool would be employed over the admissible load, it will stop automatically to protect the motor and wheel. When the load will come to the admissible level again, the tool can be started automatically.

ASSEMBLY

CAUTION:

- Always be sure that the tool is switched off and unplugged before carrying out any work on the tool.

Installing or removing the diamond wheel

Removal (Fig. 5, 6 & 7)

Loosen and remove the bolt with the hex wrench.

Open the cover while holding the tool base with a hand as shown in the figure.

NOTE:

- The tool base will open at a stroke by the spring force. Rotate the diamond wheel while pressing the shaft lock until it engages. Remove the lock nut by rotating it counterclockwise with the lock nut wrench. Remove the diamond wheel and space rings.

Adjusting the groove width (the distance between the two diamond wheels)

The width of grooving in the workpiece can be adjusted by changing the number of the space rings as shown in the table. (Fig. 8)

Installation (Fig. 9)

Determine the distance of the two blades according to the table.

To install the diamond wheel, mount it carefully onto the spindle, making sure that the direction of the arrow on the surface of the diamond wheel matches the direction of the arrow on the tool. Install space ring and lock nut.

Tighten the lock nut securely clockwise with the lock nut wrench while pushing down the shaft lock.

Return the cover and the base to the original position and tighten the bolt to secure them.

Front handle (Fig. 10 & 11)

The angle of installation of the front handle is changeable.

To change its position, loosen the two bolts on both sides of the front handle with the hex wrench and move the front handle to your desired position.

NOTE:

- When the handle cannot be moved easily, loosen the bolts furthermore.

To secure the handle, tighten the two bolts firmly.

The front handle can be shifted sideways.

To shift it, loosen and remove the two bolts on both sides of the front handle.

Remove the cam and install it on the opposite side as shown in the figure.

Insert the longer bolt to the hole in the handle on the side close to the installed cam and the shorter bolt on the opposite side.

Then tighten the two bolts firmly.

Connecting to vacuum cleaner (Fig. 12)

When you wish to perform cleaner operation, connect a vacuum cleaner to your tool. Connect a hose of vacuum cleaner to the dust nozzle.

NOTE:

- The dust nozzle can be rotated freely so that you can use it at any angle according to your operation.

Hex wrench storage (Fig. 13)

When not in use, store the hex wrench as shown in the figure to keep it from being lost.

OPERATION

CAUTION:

- Be sure to pull the tool when cutting a workpiece.
- Use this tool for straight line cutting only. Cutting curves can cause stress cracks or fragmentation of the diamond wheel resulting in possible injury to persons in the vicinity.
- After operation, always switch off the tool and wait until the wheel has come to a complete stop before putting the tool down.
- Always use the front grip and firmly hold the tool by both front grip and main handle during operations.

Adjust the front handle to appropriate position for your work by referring to the "Front handle" in the section "ASSEMBLY".

Hold the tool firmly with both hands. First keep the wheel without making any contact with a workpiece to be cut. Then turn the tool on and wait until the wheel attains full speed.

The cut is made by pulling the tool toward you (not by pushing away from you). Align the notch on the base with your cutting line, push down the front handle gently until it stops and then pull the tool slowly to perform a cut.

(Fig. 14)

Switch off the tool in the position posed when finishing a cut. Raise the tool after the wheel comes to a complete stop.

Remove the remaining portion between the two blade passage by other appropriate tools.

MAINTENANCE

CAUTION:

- Always be sure that the tool is switched off and unplugged before attempting to perform inspection or maintenance.

The tool and its air vents have to be kept clean. Regularly clean the tool's air vents or whenever the vents start to become obstructed. (Fig. 15)

Dressing diamond wheel

If the cutting action of the diamond wheel begins to diminish, use an old discarded coarse grit bench grinder wheel or concrete block to dress the diamond wheel. To do this, tightly secure the bench grinder wheel or concrete block and cut in it.

To maintain product SAFETY and RELIABILITY, repairs, carbon brush inspection and replacement, any other maintenance or adjustment should be performed by Makita Authorized Service Centers, always using Makita replacement parts.

ACCESSORIES

CAUTION:

- These accessories or attachments are recommended for use with your Makita tool specified in this manual. The use of any other accessories or attachments might present a risk of injury to persons. Only use accessory or attachment for its stated purpose.

If you need any assistance for more details regarding these accessories, ask your local Makita service center.

- Diamond wheels