

REID
LIFTING

LIGHTWEIGHT | PORTABLE | SAFE

PORTA-GANTRY
 20001

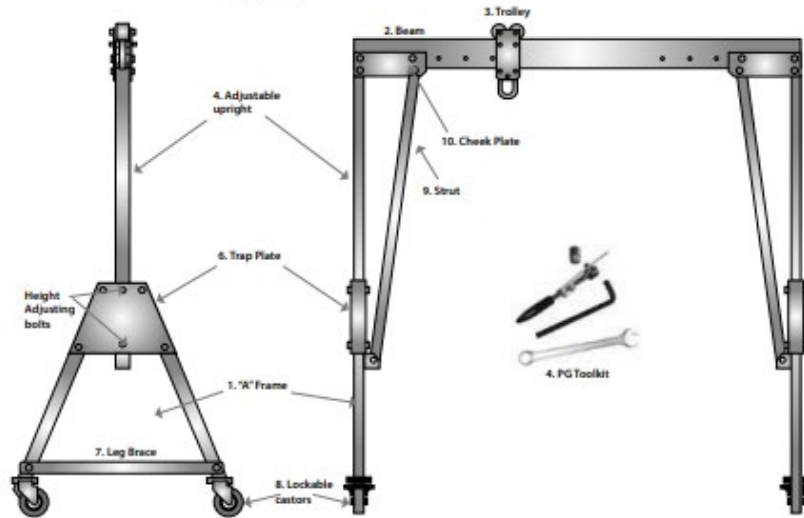

PORTA-GANTRY
 500-3000



PORTA-GANTRY

PORTA-DAVIT

T-DAVIT

PORTA-QUAD

PORTA-LIFTER

Assembly & Operation Guide
 for PORTA-GANTRY systems with Working Load Limit
 (WLL) 500 to 3000kg

ASSEMBLY & OPERATION GUIDE

CONTENTS

INTRODUCTION

CORRECT OPERATION:

- Inspection prior to initial operation
- Inspection before starting work
- Maximum capacity
- Notes for correct usage
- Danger zones
- Attaching the load
- Temperature range
- Regulations
- Maintenance/Repair
- Inspection/Maintenance
- Regular Inspections

ASSEMBLY INSTRUCTIONS

VARIANTS & OPTIONS

- Wind Up Jack Legs
- Ratchet System
- Customised configurations
- PG5000

PORTA-GANTRY®
500-3000



LIGHTWEIGHT || PORTABLE || SAFE

INTRODUCTION

All users must read these operating instructions carefully prior to the initial operation. These instructions are intended to acquaint the user with the machine/hoist and enable him/her to use it to the full extent of its intended capabilities.

The operating instructions contain important information on how to handle the gantry in a safe, correct and economic way. Acting in accordance with these instructions helps to avoid dangers, reduce repair costs and down time and to increase the reliability and lifetime of the gantry frame.

Anyone involved in doing any of the following work with the gantry frame must read the operation instructions and act accordingly:

- operation, including preparation, trouble shooting during operation and cleaning
- maintenance, inspection, repair
- transport

Apart from the operating guide, health & safety and accident prevention act valid for the respective country and area where the gantry frame is used, the commonly accepted regulations for safe and professional work must be adhered to.

N.B. This document should form an element of the overriding Risk Assessment and Method Statement required for each lift.

PORTA-GANTRY®

500-3000



500 - 3000Kg WLL 1-4 People 92-294Kg flatpack

CORRECT OPERATION

Inspection prior to initial operation:

Each gantry frame must be inspected prior to initial operation by a competent person. The inspection is visual and functional and shall establish that the A frame is safe and has not been damaged by incorrect assembly, transport or storage. Inspections are instigated by the user.

Inspection before starting work:

The inspection procedure requires that a valid inspection/test certificate has been submitted to and checked by the user.

Before starting work inspect the gantry frame assembly and all load-bearing components for visual defects. Furthermore, test the trolley for free movement along the beam.

Ensure that the overall WLL limit is adhered to – following the necessary Risk Assessment and Method Statement.

Maximum capacity:

The PORTA-GANTRY assembly is designed to lift and lower loads up to the related capacity. The capacity indicated on the frame is the maximum weight load limit (WLL) or safe working load (SWL) which must not be exceeded (definition is country dependent).

Each lift must be properly planned and the weight of the load to be lifted must be known by the operator.

NOTE:

- 1 We recommend the use of a load-sensing device on all lifts.
2. The Gantry should **NOT** be moved under load. Any deviation from this should be supported by a risk assessment and method statement.
3. The WLL (or SWL) rating must **NOT** be exceeded – risk assessment & method statement must consider additional loading in "wet lift" situations

NOTES FOR CORRECT USAGE

Do not throw the gantry frame or its components down or stack items on top of it. Always place properly on the ground avoiding damage to the equipment.

- Assemble only as instructed above.
- The beam must be horizontal prior to any lift
- Do not use the gantry frame if the trolley does not run freely along the beam.
- Attach hoist only to the lifting point on the trolley.
- Avoid side pull. Lift only when load chain(s) form a straight and vertical line between load and lifting attachment point on the gantry trolley.
- Do not allow load to swing.

- Only raise and lower loads when foot brakes are 'on'.

The gantry is not to be moved under load except when a Competent Person or authority approves a risk assessment and a method statement for a particular reason.

Danger zones:

- Do not lift or transport loads while personnel are in the danger zone.
- Do not allow personnel to pass under a suspended load.
- After lifting, a load must not be left unattended for a long period of time.
- Start moving the load down the beam only after it has been attached correctly and all personnel are clear of the danger zone.

Attaching the load:

The operator must ensure that the hoist is attached in a manner that does not expose him or other personnel to danger by the hoist, chain(s) or the load.

Temperature range:

The PORTA-GANTRY frame assembly can be operated in ambient temperatures between -20°C and +50° (-4°F to 122°F). Consult your supplier in case of extreme working conditions.

Regulations:

The Supply of Machinery (Safety) Regulations (2008) (S.I. 2008/1597), The Provision and Use of Work Equipment Regulations 1998 (S.I. 1998 No. 2306), The Lifting Operations and Lifting Equipment Regulations 1998 (S.I. 1998 No. 2307), Machinery Directive 2006/42/EC and/or safety regulations of the respective country for using manual lifting equipment must be strictly adhered to.

Maintenance/Repair:

In order to ensure correct operation not only the operations instructions, but also the conditions for inspection and maintenance must be complied with. If defects are found stop using the gantry frame immediately.

INSPECTION/MAINTENANCE:

Regular inspections:

To ensure that the gantry frame remains in safe working order they are to be subjected to regular inspections by a competent person. Inspections are to be annual unless adverse working conditions or profile of use dictate shorter periods. The components of the gantry frame are to be inspected for damage, wear, corrosion or other irregularities. To check for worn parts it may be necessary to disassemble the gantry frame. Repairs should only be carried out by an approved specialist workshop that uses original spare parts.

Inspections are instigated by the user.



LIGHTWEIGHT ■ PORTABLE ■ SAFE

ASSEMBLY INSTRUCTIONS:

NB: Appropriate PPE should be worn

- Gloves • Protective footwear • Hard hat



PORTA-GANTRY system delivered Flat Packed on a Pallet:

- 2 x A-Frames
- 1 Trolley



Beam sometimes shipped separately



Gantry Tool Set:

- Ratchet handle
- 1/2" sq drive
- 24mm socket
- 24mm combination spanner
- 14mm long series allen key

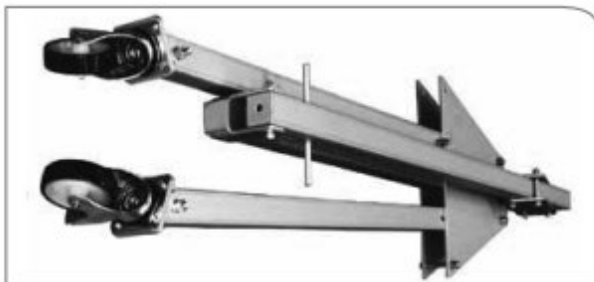

A-Frame prior to assembly



Assemble each A-Frame by:

- Position legs & bolt in place
- Attaching leg brace

The unit is most easily assembled with the A-Frames at their lowest height setting and this is the recommended position to start from.

PORTA-GANTRY®

500-3000



500 -
3000Kg
WLL



1-4
People



92-294Kg
flatpack



Apply the castor brakes

Put brakes on only with protective footwear

DO NOT USE HANDS

Lock casters in position in line with the A-Frame Tie Bar, as shown:



Pre Assembly visual check

- Beam
- Trolley
- 2 x A-Frames
- Tool Set (Option)



Check Plates bolts 1 & 2



Lay the two A-Frames a beam length apart on a flat surface in line with each other with the castor wheels outward and brakes on.

Lay the beam on the A-Frames, resting on Bolt 1 on each cheek plate



Offer one end of the beam to the rear bolt-hole on the cheek-plate (Bolt 1) and insert a bolt. Put on plain & spring washers and nut, finger tight.



Visual Check



Thread beam trolley over the other end of the beam and lock with friction brake at approximately centre position.

Assess whether the lifting device (usually chain block / hoist) needs to be attached to the trolley at this stage or when fully assembled. Heavier hoists are best attached at this stage.



Offer the beam to the rear bolt-hole on the cheek-plate (Bolt 1) and insert a bolt. Put on plain & spring washers and nut finger tight.

PORTA-GANTRY®

500-3000



500 -
3000Kg
WLL

1-4
People

92-294Kg
flatpack



Visual Check



At this stage it may be useful to attach the lifting device to the trolley in order to avoid having to lift and attach when gantry is fully erect. This avoids a working at height problem when attaching a hoist.



Lift - Keeping hands clear of potential "Pinch" area marked with warning tape

With the help of another person, scissor the beam and A-Frame into position (using the first bolt as a hinge)

BE CAREFUL NOT TO TRAP ANY HANDS IN THIS OPERATION

Chain Hoist opposite end to lift



Insert the second bolt into the cheek-plate. Tighten both bolts. (Do not over tighten)

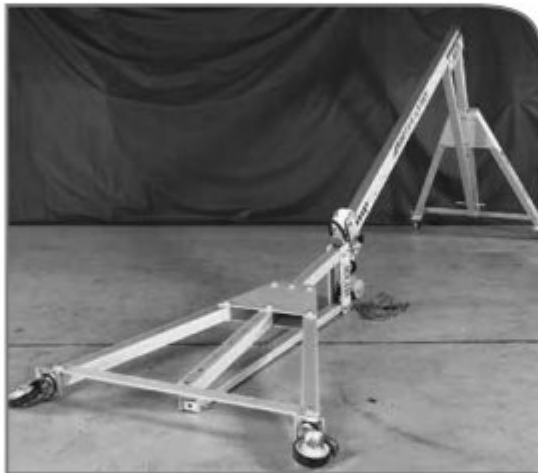

Visual Check



Move trolley to other end of beam, opposite to the end to be raised, and secure by tightening the trolley knob.

(For additional safety whilst the beam is at such an angle a spare bolt can be temporarily be placed in an adjustment point on the beam to prevent the trolley slipping down the beam)

PORTA-GANTRY®

500-3000



500 -
3000Kg
WLL

1-4
People

92-294Kg
flatpack



Repeat the scissor activity
at the opposite end of the
gantry.



Insert and tighten the final
beam bolt.



If the hoist is not already
attached to the suspension
point on the trolley, do so now
(using stepladder if height
setting requires).

If this is not safe, disassemble
the gantry and re-start adding
the hoist prior to raising the
A-Frames.

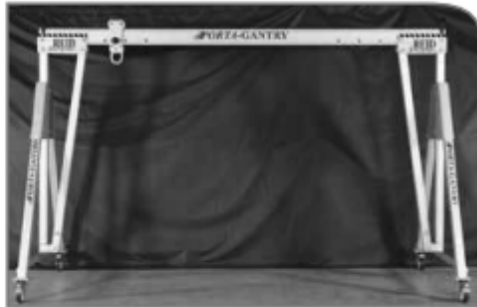

The gantry is now erect at its lowest height setting.

Tighten all bolts to 27 Nm (20 ft lbs)

(If raising the beam height – leave the two height adjustment bolts loose on each upright – see next image)

Decide on the height required (always using the lowest setting for the work in hand).

Adjust the upright position at one A-Frame (a 2 man operation – one on the bolts and one on the upright) by removing 2xUpright securing bolts, moving the upright to the appropriate setting by lifting from the strut handle. Re-secure with bolts, nuts & washers (Do not over tighten).

Repeat the height adjustment at the opposite end.

N.B. Ensure the beam is horizontal prior to any lift – see Method Statement.

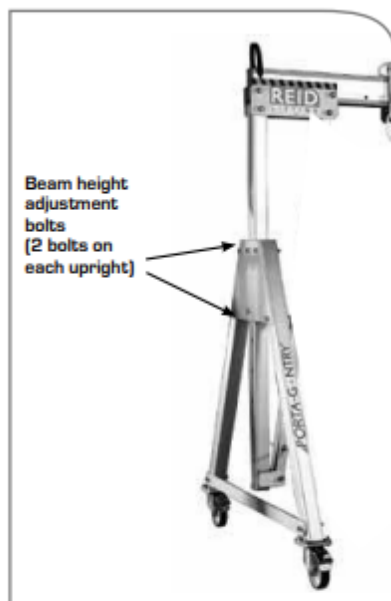

Release trolley brake and wheel brakes to position the structure over the lifting point.

PORTA-GANTRY®

500-3000



500 - 3000Kg WLL 1-4 People 92-294Kg flatpack

VARIANTS & OPTIONS:

- Wind Up Jack Legs
- Ratchet Beam Elevation System:
- Customised configurations
- PG5000

Wind Up Jack Leg Option (WUJL):

WUJL option may be fitted to the gantry – if so this gives fine adjustment in the height setting (300mm total lift on the uprights) and gives independent foot adjustment, particularly useful on uneven ground.

If the windup jack legs are fitted the following points must be observed:

1. Check whether the castors fitted are Load Rated (or Pneumatic).

Note: When 'all-terrain', pneumatic castors that are not rated for lifting, the WUJL system must always be applied prior to performing any lift. If load rated castors are fitted the operator can choose whether the castors or WUJL take the load on each foot of the gantry.

2. When transporting over ground or manoeuvring the gantry, into position, always have the stands in the 'parked' position as in figure.1 below or remove if required.

3. Position the gantry for the lift before setting the heights with the stand-off.
4. Before lifting ensure all jacks are in the correct lifting position and are secured with locking pins and clips as in figure.2.
5. Manually raise each leg/castor in turn and set the height by rotating jack handle clockwise
6. Having set the adjustment of all four legs, stand back from the gantry and ensure that the gantry uprights are vertical and the beam is horizontal as in figure.3.
7. If the ground that the load spreading feet are on is soft and likely to sink when the load applied put boards under the feet to spread the load further.
8. Having performed the lifting operations, put the stands in the 'park' position and disassemble.



Fig.1 Wind Up Jack Leg in 'parked' position



Fig.2 Jacks secured with locking pins and clips



Fig.3 Wind Up Jack Leg system in place, used with pneumatic 'all-terrain' castors.



Fig. 4 Example application



Beam Height Adjustment using Ratchet System option:

[Two Person Operation Recommended - one on the bolts and one on the upright]
Always wear gloves when using this item.

1. Decide on the height required (always use the lowest setting for the work in hand).
2. Remove 2-off upright bolts.
3. Operate ratchet to adjust height to required setting, ensuring that the bolt holes are aligned.
4. Re-secure with 2-off upright bolts, nuts and washers.
5. Repeat steps 2-4 on the second A-Frame, ensuring that both A-Frames finish at the same height.
6. Check all bolts on the gantry are secure.
7. If the hoist is not already attached to the suspension point on the trolley, do so now (using stepladder if height setting requires). If this is not safe, disassemble gantry and re-start from page 8 of the Gantry Assembly Instructions.



Customised configurations:

For customised systems additional assembly and operation information will be provided as required

PORTA-GANTRY 5000:

Unique lightweight, portable gantry system with WLL to 5000kg

See separate Assembly & Operating Guide



E&OE

PORTA-GANTRY®

500-3000



500 - 3000Kg WLL

1-4 People

92-294Kg flatpack

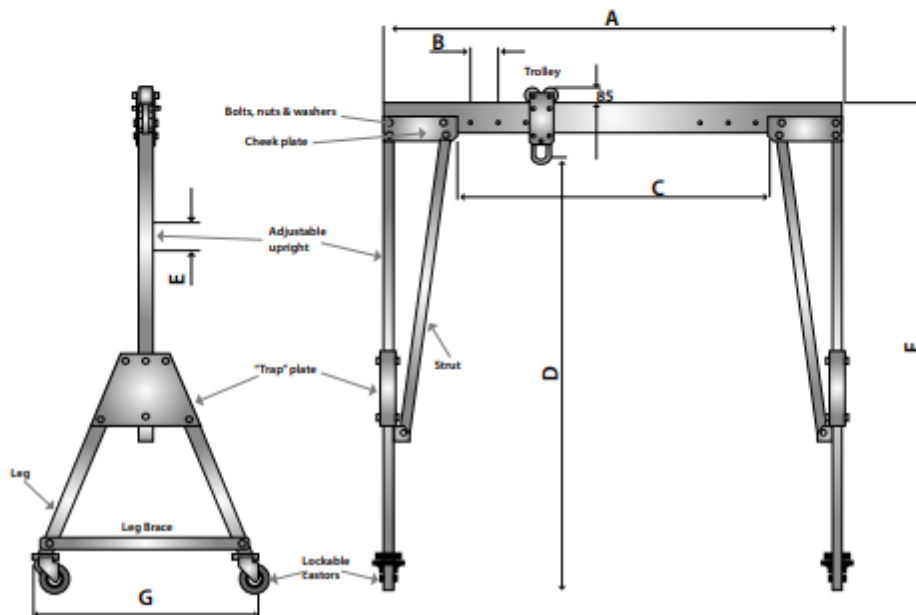

REID PORTA-GANTRY STANDARD UNIT DATA SHEET													
Icon	Overall Beam Length	Span Adjustment Increment	Max Working Span	Max Height to Lifting Eye	Height Adjustment Increment	Min Height to Lifting Eye	Max Height to Top of Beam	Max Width Across Legs	Assembled Weight (Ex Trolley)	Beam Weight	A Frame Weight	Icon	Icon
	A	B	C	D	E	F	G	G	Kg	Kg	Kg		Kg
WLL Kg / Frame Size	mm	mm	mm	mm	mm	mm	mm	mm	Kg	Kg	Kg		Kg
500 (S)	2500	200	1580	2361	150	1811	2678	1220	85	19	33	1	92
1000 (M)	3920	200	3000	2854	150	2104	3171	1429	109	29	40	2	118
2000 (I)	4570	200	3850	3198	200	2198	3514	1728	125	33	48	2	132
3000 (T)	4570	200	3850	4089	200	2889	4405	2011	205	43	82	3	212
5000* (I)	4570	200	3850	3188	200	2188	3618	1728	285	71	97**	3/4	275
5000* (T)	4570	200	3850	4040	200	2840	4485	2011	284	71	108**	3/4	294

All WLL ratings can be produced in each standard frame size. Custom spans, height and Working Load Limits (WLL) on application.

*N.B. FG5000 beam depth (250mm), trolley depth (570mm) & trolley top above beam (125mm) are larger than the standard beam depth (152mm), trolley depth (385mm) and trolley top above beam (85mm)

** This weight includes the stabiliser leg option. Please note that dimensions may vary marginally. NE. No leg brace fitted on 'S' systems

Patent Application Numbers: 0722596.4, GB 2457875A, DB03120.5 International Patent Application Numbers: PCT/EP2008/065675, PCT/GB2009/000467



QUALITY & SAFETY

ACCREDITATIONS

Quality and Safety are key themes throughout this document and the REID Lifting ethos.

It is with this in mind that we have undertaken external accreditations to ensure we stay focused on what is important to our clients and users and ahead of market trends and developments in Safety and Quality systems.

REID Lifting has been successfully audited by Lloyds Register (LRQA) for approval of its Integrated Management System combining quality systems management, environmental issues and the Health and Safety practices within the company.

REID Lifting holds the following certifications:

- **ISO 9001** - Specifies requirements for a quality management system for any organisation that needs to demonstrate its ability to consistently provide product that meets customer and applicable regulatory requirements and aims to enhance customer satisfaction.
- **ISO 14001** - Specifies the requirements for implementing environmental management systems throughout all areas of the company.
- **OHSAS 18001** - Occupational Health and Safety Managements Systems.
- **LEEA Membership** - REID Lifting Ltd is a full member of the Lifting Equipment Engineers Association (membership 000897). REID Lifting conforms to the main aims of the Association which is to achieve the highest standards of quality and integrity in the operations of members. Their entry qualifications are demanding and strictly enforced through technical audits based on the Technical Requirements for Members.



Conformité Européenne (CE)

REID Lifting's products have been designed, tested and approved (as appropriate) by the Conformité Européenne (French for European Conformity). This certifies that REID Lifting's products meet the demands of the European Directives regarding Health and Safety requirements.

The Queen's Award for Enterprise Innovation:

REID Lifting Ltd has been awarded this prestigious award for innovative design and development of lightweight, portable and safe lifting solutions.

TESTING

Testing and Technical File review are integral parts of our design and manufacturing process – to externally verify the products, where appropriate, using government approved Notified Bodies.

All REID Lifting products are type tested at NAMAS accredited laboratories and every individual system is tested to 150% of WLL rating.

Full product design & development Technical Files are available for inspection.

PRODUCT IPR

Design Rights apply to all REID Lifting Ltd products REID PATENTS in place, or pending, for:

- PORTA-GANTRY
- T-DAVIT
- SNAPPER

All product names are Trade Marks of REID Lifting Ltd:

- PORTA-GANTRY
- PORTA-DAVIT
- PORTA-BASE
- T-DAVIT
- PORTA-QUAD
- SNAPPER
- PORTA-LIFTER Manhole Lifter

REID LIFTING

LIGHTWEIGHT ■ PORTABLE ■ SAFE



Reid Lifting Limited
Unit 1 Severnlink
Newhouse Farm Industrial Estate
Chepstow
Monmouthshire NP16 6LN
enquiries@reidlifting.com
Tel: +44 (0)1291 620796
Fax: +44 (0)1291 626490



Reid Lifting France
16 Quater
Avenue Martyrs de la Resistance
56250
Elven, France
reidlifting@wanadoo.fr
Tel: +33 (0)297 53 32 99
Fax: +33 (0)297 53 04 86



BPF Distributors & Pumps Limited
Industrial Estate, Killough Road,
Downpatrick, Co. Down BT30 6LJ
NI
Tel: +44 (0)28 4461 5777
Fax: +44 (0)28 4461 4250
ROI
Tel: +353 (0)1 478 0665
Fax: +353 (0)1 478 0678
info@bpf-td.com & www.bpf-td.com



KAMAB Lyftsystem AB
Box 74, Rällarvägen 15
184 21 Åkersberga, Sweden
Tel: +46 (0)8540 69180
Fax: +46 (0)8540 60566
www.kamab.nu



Thern, Inc.
5712 Industrial Park Road
PO Box 347
Winona, MN 55987
USA
Phone: 507.454.2996
Toll Free: 800.843.7648
Fax: 507.454.5282
info@thern.com

REID Lifting – the best night's sleep in the lifting industry

- Systems are type tested at NAMAS accredited laboratories
- Every individual system is tested to 150% of WLL rating prior to shipment
- Full product design & development Technical Files are available for inspection
- Lifting Equipment Engineers Association (LEEA) full membership
- ISO9001 Quality Management Systems accreditation
- ISO14001 accreditation environment management systems and standards
- OHSAS18001 Occupational Health and Safety Management accreditation
- Certification of products by relevant recognised bodies from sockets to systems
- Safe assembly, use and maintenance manuals and training are available for all systems

WHAT'S NEXT

Further information and support can be found on our website www.reidlifting.com



CALL US
+44 (0)1291 620796



EMAIL US
enquiries@reidlifting.com



WEB
www.reidlifting.com

N.B. This document should form an element of the overriding Risk Assessment and Method Statement required for each lift.



