

## Makita Cordless Biscuit Joiner LXT 18V

Cordless Plate Joiner powered by an 18V Li-Ion battery, ideal for cutting crescent shaped slots for the placement of flat wooden dowels or biscuits for a plunging action. Compact and lightweight design for high manoeuvrability and easy handling, without the hassle and restrictions that come with traditional corded power tools.



### User Benefits

- Compact and lightweight design
- Anti-restart function (with warning lamp)
- Shaft lock for easy blade change
- Angle adjustable fence with positive stops at 0°, 45° and 90°
- Blade cover can be opened with clamp screws for easy blade change

### Machine Specifications

Max. Grooving Depth	20 mm
No Load Speed	6500 rpm
Overall Length	351 mm
Rated Voltage	18 V
Net Weight	3.0 kg

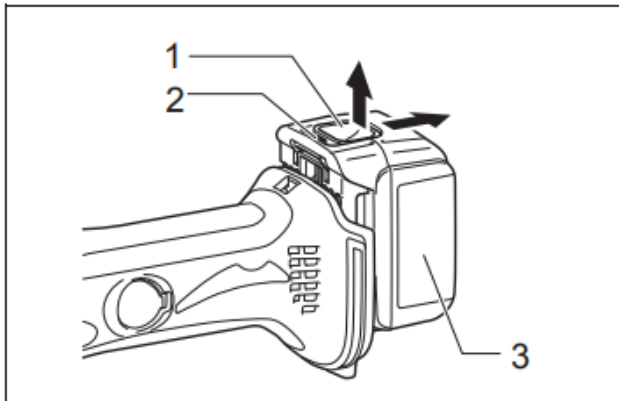

**1** 012510

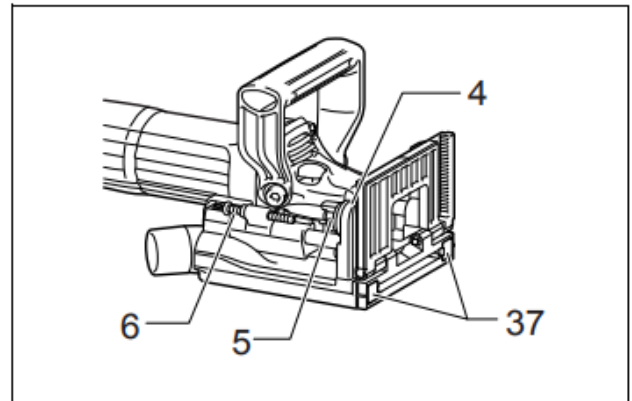

**2** 012682

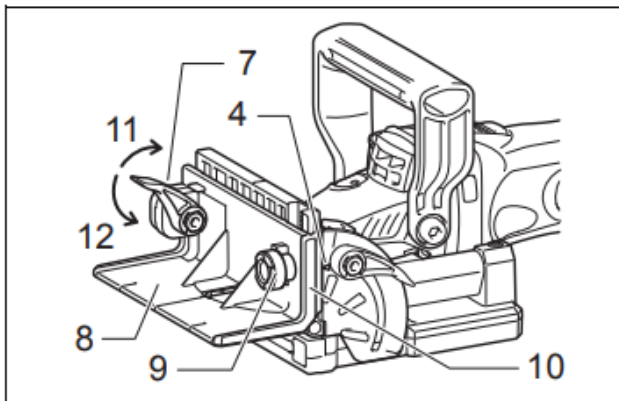

**3** 012497

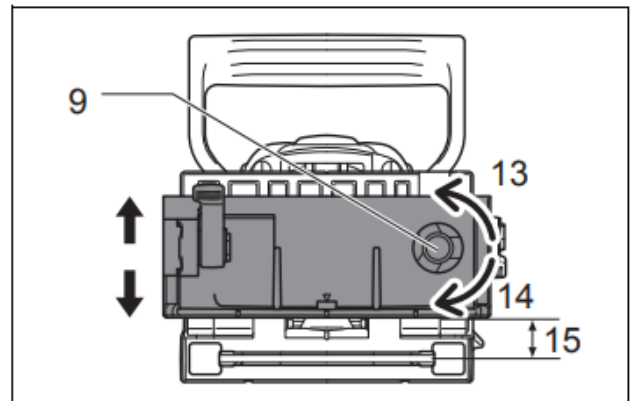

**4** 012498

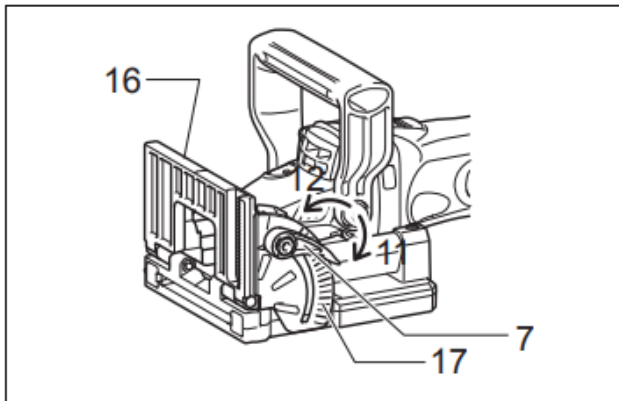

**5** 012499

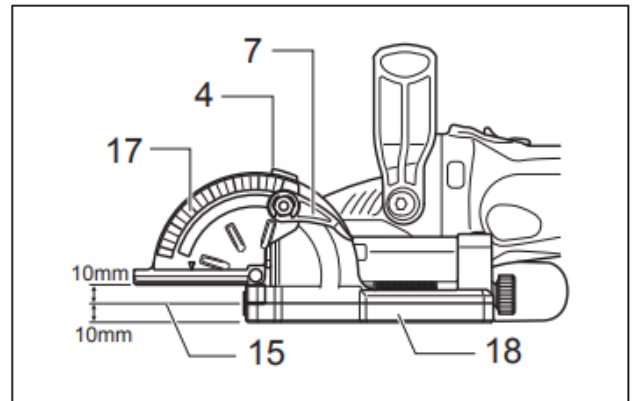

**6** 012500

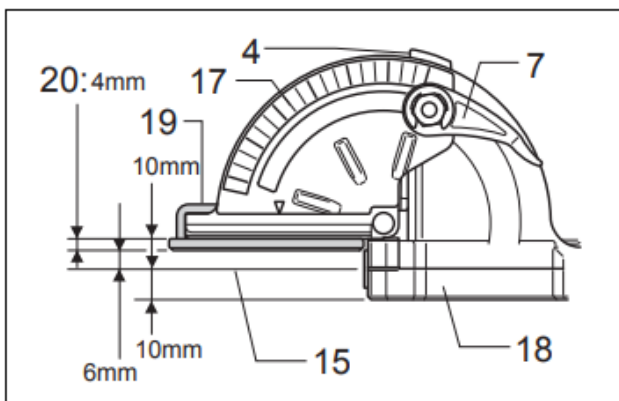

**7** 012258

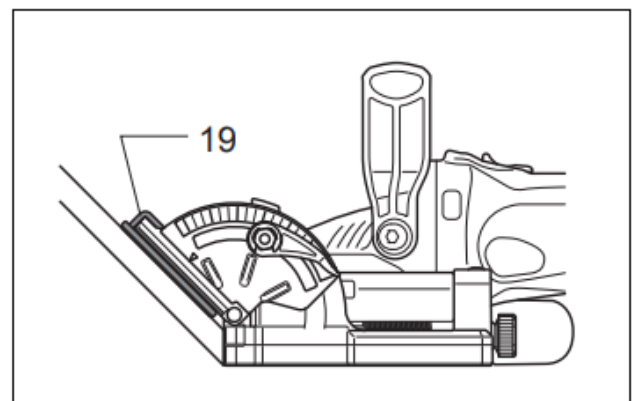

**8** 012501

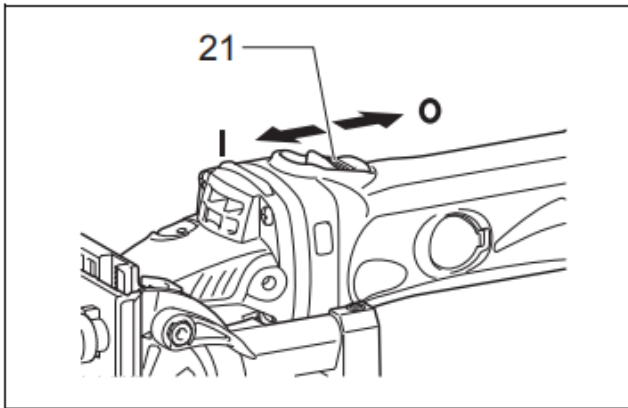

**9** 012512

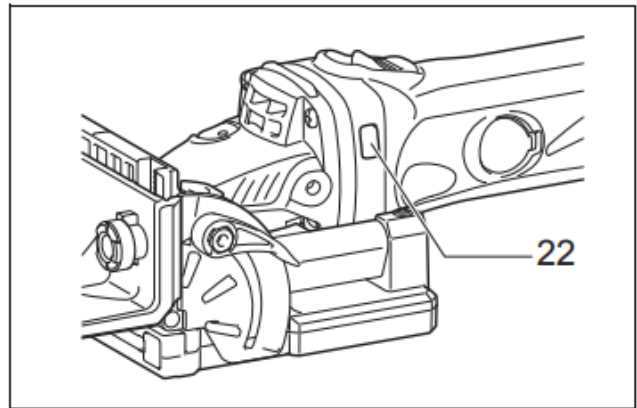

**10** 012513

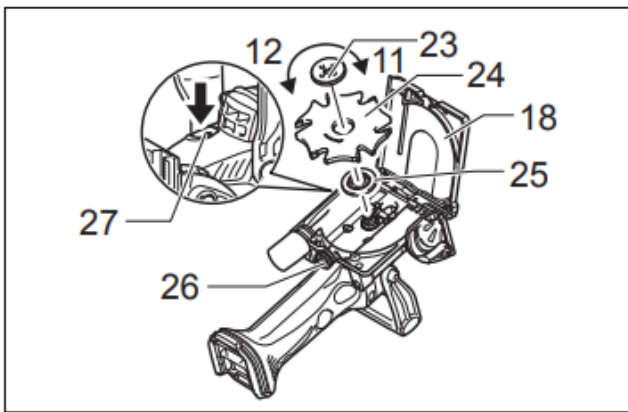

**11** 012502

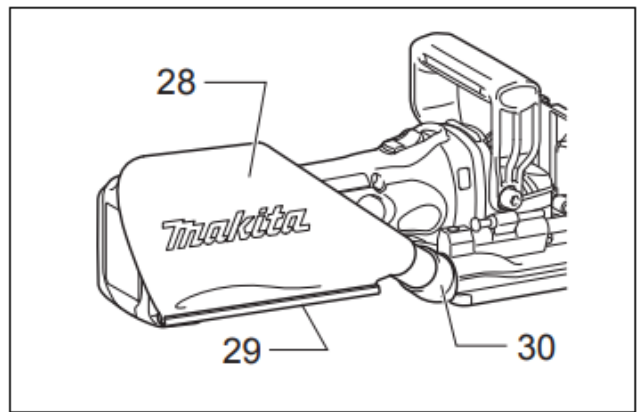

**12** 012503

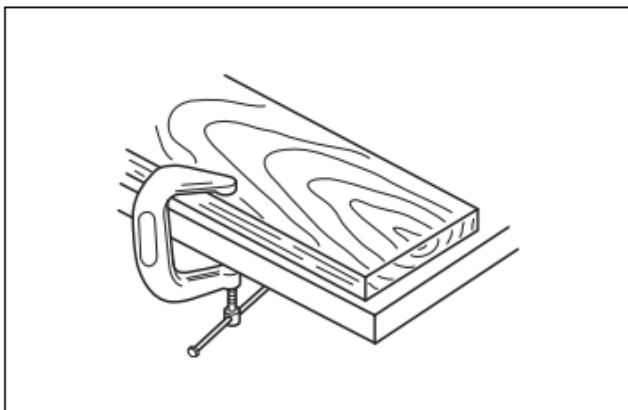

**13** 004589

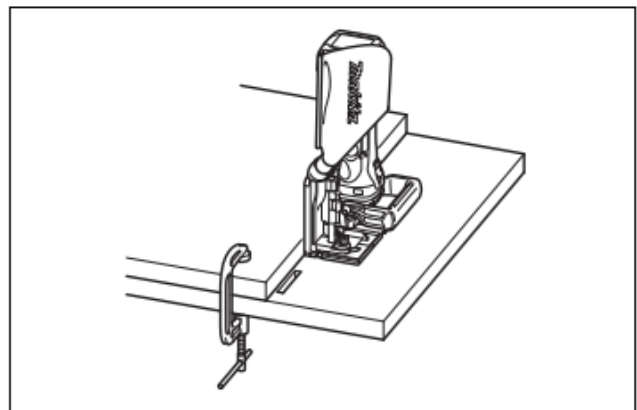

**14** 012504

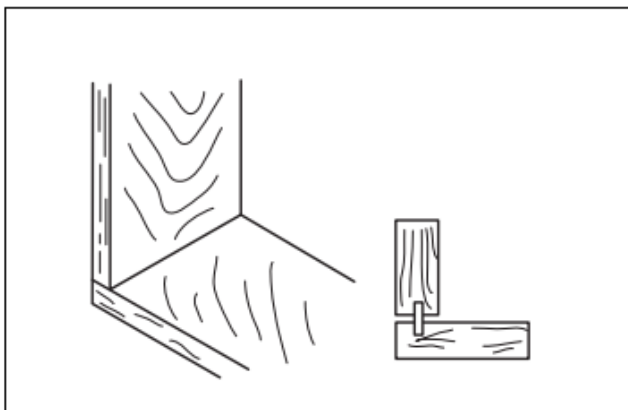

**15** 004584

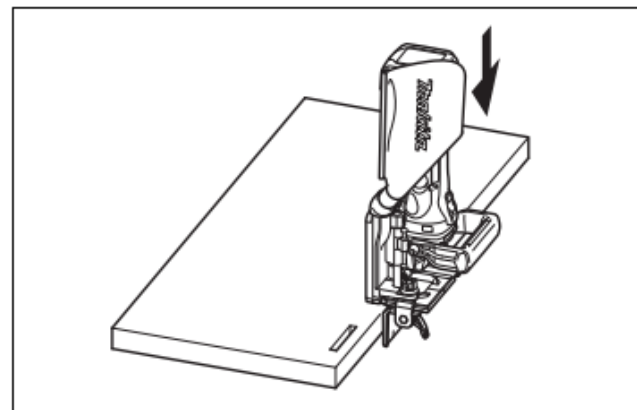

**16** 012505

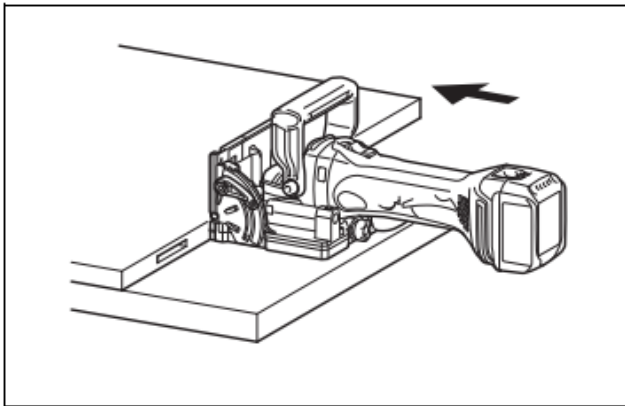

17

012506

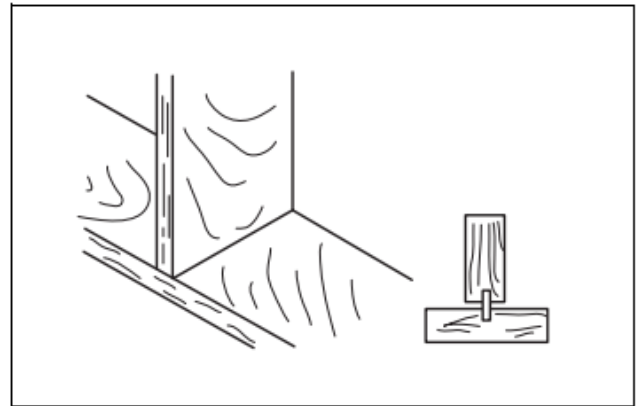

18

004585

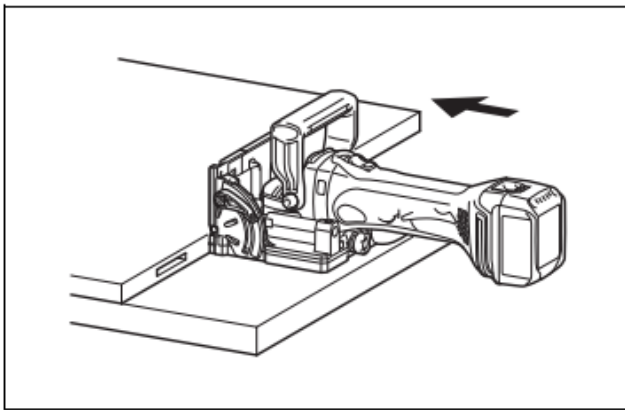

19

012506

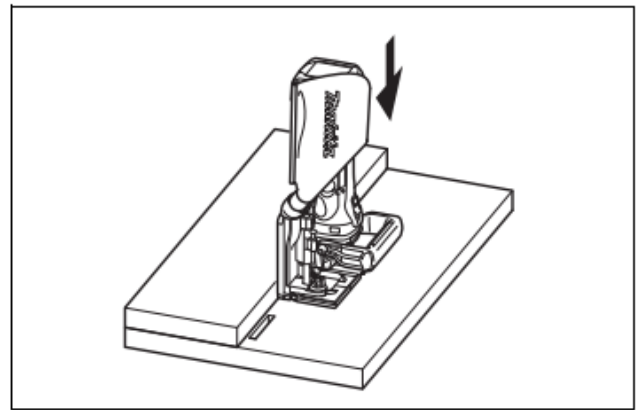

20

012507

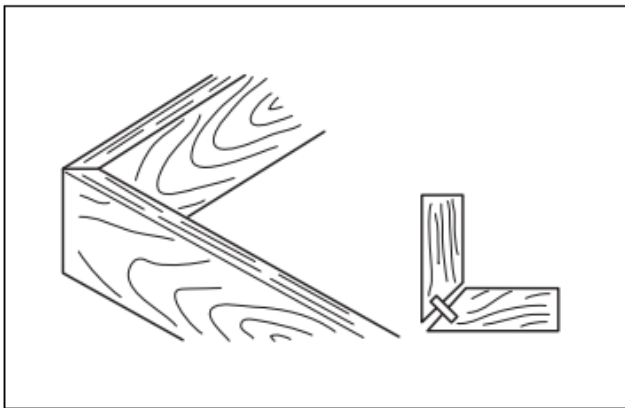

21

004586

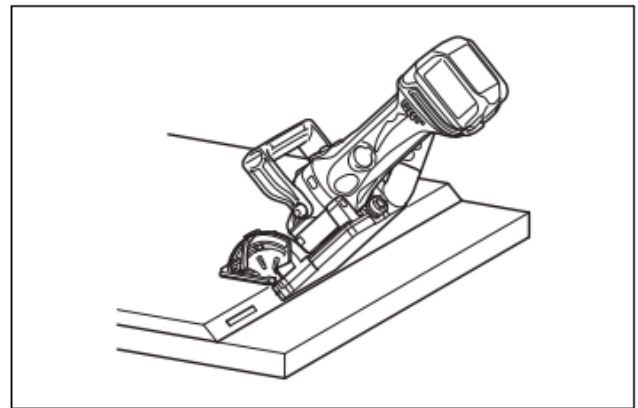

22

012508

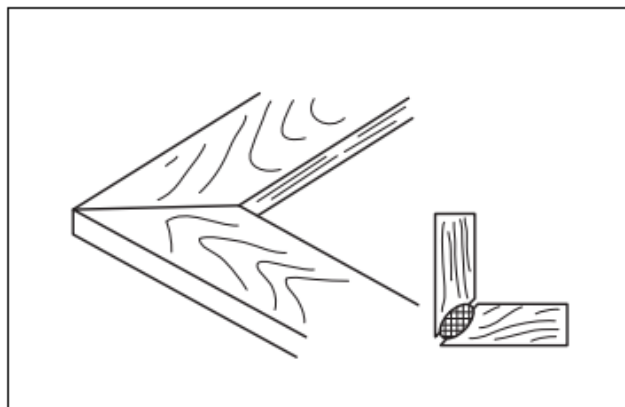

23

004587

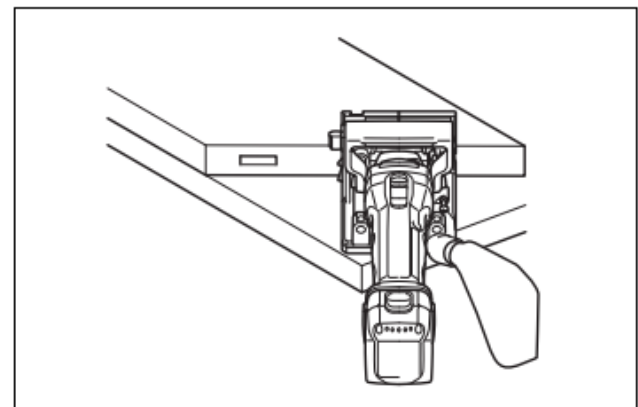

24

012509

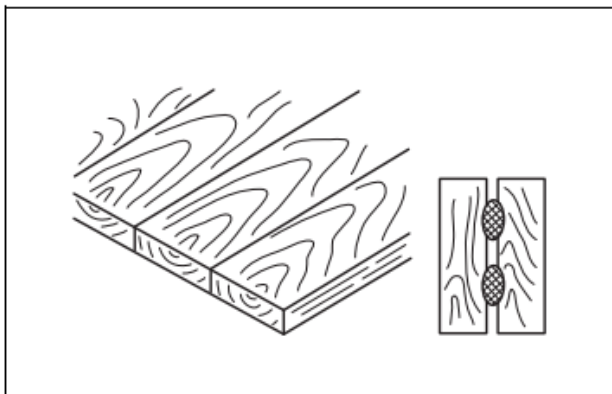

25

004588

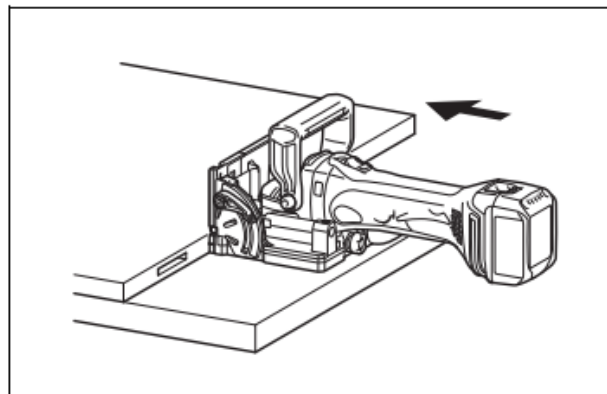

26

012506

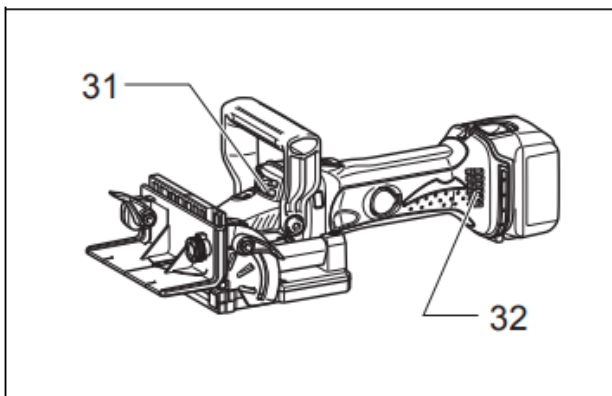

27

012518

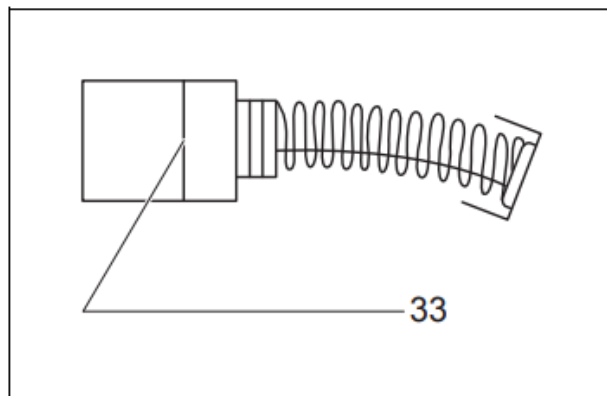

28

001145

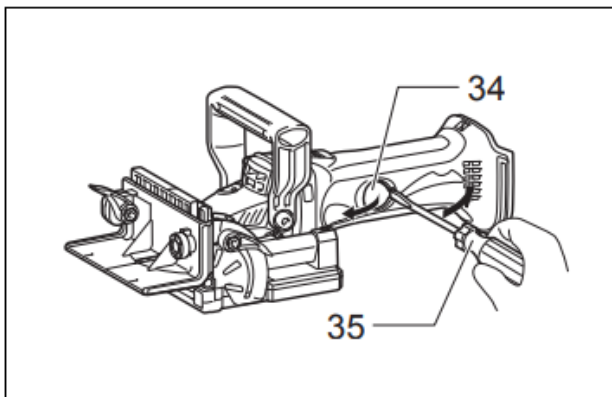

29

012514

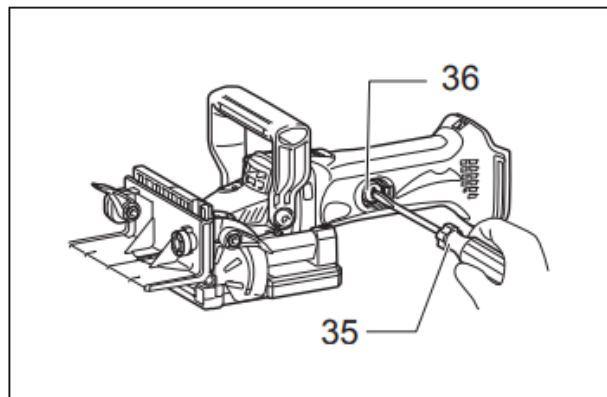

30

012515

**ENGLISH** (Original instructions)

**Explanation of general view**

- 1 Button
- 2 Red indicator
- 3 Battery cartridge
- 4 Pointer
- 5 Stopper
- 6 Adjusting screw
- 7 Lock lever
- 8 Angle guide
- 9 Knob
- 10 Scale
- 11 Tighten
- 12 Loosen
- 13 Down

- 14 Up
- 15 Center of blade thickness
- 16 Fence
- 17 Angle scale
- 18 Blade cover
- 19 Set plate
- 20 Thickness of set plate
- 21 Slide switch
- 22 Indication lamp
- 23 Lock nut
- 24 Plate joiner blade
- 25 Inner flange
- 26 Clamp screw

- 27 Shaft lock
- 28 Dust bag
- 29 Fastener
- 30 Dust nozzle
- 31 Exhaust vent
- 32 Inhalation vent
- 33 Limit mark
- 34 Holder cap cover
- 35 Screwdriver
- 36 Brush holder cap
- 37 Rubber spike

- Due to our continuing program of research and development, the specifications herein are subject to change without notice.
- Specifications and battery cartridge may differ from country to country.
- Weight, with battery cartridge, according to EPTA-Procedure 01/2003

ENE013-1

#### **Intended use**

The tool is intended for cutting crescent shaped slots for the placement of flat wooden dowels or biscuit by a plunging action.

GEA010-1

#### **General Power Tool Safety Warnings**

 **WARNING** Read all safety warnings and all instructions. Failure to follow the warnings and instructions may result in electric shock, fire and/or serious injury.

Save all warnings and instructions for future reference.

GEB093-1

#### **CORDLESS PLATE JOINER SAFETY WARNINGS**

1. **Blades must be rated for at least the speed marked on the tool.** Blades running over rated speed can fly apart and cause injury.
2. **Always use the guard.** The guard protects the operator from broken blade fragments and unintentional contact with the blade.
3. **Use only the blades specified for this tool.**
4. **Never operate the tool with the blade locked in exposed position or without the blade cover secured properly in place.**
5. **Make sure that the blade slides smoothly before operation.**

6. **Check the blades carefully for cracks or damage before operation. Replace cracked or damaged blades immediately.**
7. **Make sure that the flange fits in the arbor hole when installing the blade.**
8. **Inspect for and remove all nails or foreign matter from the workpieces before operation.**
9. **Always place the workpieces on a stable workbench.**
10. **Secure the workpieces firmly with clamp or vise.**
11. **NEVER wear gloves during operation.**
12. **Hold the tool firmly with both hands.**
13. **Keep your hands and body away from the grooving area.**
14. **Run the tool for a while without the blade pointing toward anybody. Watch for vibration or wobbling that could indicate poor installation or a poorly balanced blade.**
15. **Never reach your hands underneath the workpieces while the blade is rotating.**
16. **Do not leave the tool running unattended.**
17. **Always be sure that the tool is switched off and the battery cartridge is removed before making any adjustments or replacing the blade.**
18. **Some material contains chemicals which may be toxic. Take caution to prevent dust inhalation and skin contact. Follow material supplier safety data.**
19. **Do not use blunt or damaged blades.**
20. **Do not use the tool with damaged guards.**

#### **SAVE THESE INSTRUCTIONS.**

##### **WARNING:**

**DO NOT** let comfort or familiarity with product (gained from repeated use) replace strict adherence to safety rules for the subject product. **MISUSE** or failure to follow the safety rules stated in this instruction manual may cause serious personal injury.

ENC007-7

## IMPORTANT SAFETY INSTRUCTIONS

### FOR BATTERY CARTRIDGE

1. Before using battery cartridge, read all instructions and cautionary markings on (1) battery charger, (2) battery, and (3) product using battery.
2. Do not disassemble battery cartridge.
3. If operating time has become excessively shorter, stop operating immediately. It may result in a risk of overheating, possible burns and even an explosion.
4. If electrolyte gets into your eyes, rinse them out with clear water and seek medical attention right away. It may result in loss of your eyesight.
5. Do not short the battery cartridge:
  - (1) Do not touch the terminals with any conductive material.
  - (2) Avoid storing battery cartridge in a container with other metal objects such as nails, coins, etc.
  - (3) Do not expose battery cartridge to water or rain.

A battery short can cause a large current flow, overheating, possible burns and even a breakdown.
6. Do not store the tool and battery cartridge in locations where the temperature may reach or exceed 50°C (122°F).
7. Do not incinerate the battery cartridge even if it is severely damaged or is completely worn out. The battery cartridge can explode in a fire.
8. Be careful not to drop or strike battery.
9. Do not use a damaged battery.

## SAVE THESE INSTRUCTIONS.

### Adjusting the depth of groove (Fig. 2)

6 grooving depths can be preset according to the size of biscuit to be used.

Refer to the table below for the correspondence between the sizes marked on the stopper and the biscuit size. Fine adjustments to the grooving depth can be made by turning the adjusting screw after loosening the hex nut. This may become necessary after the blade has been resharpened a few times.

Size on stopper	0	10	20	S	D	MAX
Biscuit size	0	10	20	—	—	—
Depth of groove	8 mm	10 mm	12.3 mm	13 mm	14.7 mm	20 mm*

\* With the rubber spikes removed.

012681

### Angle guide (Fig. 3 & 4)

The angle guide height can be moved up and down to adjust the position of the blade in relation to the top of the workpiece.

To adjust the angle guide height, loosen the lock lever down and rotate the knob until the pointer points to the desired scale graduation marked on the angle guide.

Then tighten the lock lever up to secure the angle guide. The scale on the angle guide indicates the distance from the top of the workpiece to the center of the blade thickness.

The angle guide is removable from the fence according to the need of your work. To remove the angle guide, loosen the lock lever and turn the knob clockwise until it comes out of the upper end of the fence.

### Tips for maintaining maximum battery life

1. Charge the battery cartridge before completely discharged. Always stop tool operation and charge the battery cartridge when you notice less tool power.
2. Never recharge a fully charged battery cartridge. Overcharging shortens the battery service life.
3. Charge the battery cartridge with room temperature at 10°C – 40°C (50°F – 104°F). Let a hot battery cartridge cool down before charging it.
4. Charge the battery cartridge once in every six months if you do not use it for a long period of time.

## FUNCTIONAL DESCRIPTION

### ⚠ CAUTION:

- Always be sure that the tool is switched off and the battery cartridge is removed before adjusting or checking function on the tool.

### Installing or removing battery cartridge (Fig. 1)

- Always switch off the tool before installing or removing of the battery cartridge.
- To remove the battery cartridge, slide it from the tool while sliding the button on the front of the cartridge.
- To install the battery cartridge, align the tongue on the battery cartridge with the groove in the housing and slip it into place. Always insert it all the way until it locks in place with a little click. If you can see the red indicator on the upper side of the button, it is not locked completely. Install it fully until the red indicator cannot be seen. If not, it may accidentally fall out of the tool, causing injury to you or someone around you.
- Do not use force when installing the battery cartridge. If the cartridge does not slide in easily, it is not being inserted correctly.

### Fence (Fig. 5 & 6)

#### NOTE:

- Remove the angle guide according to the need of your work when using the tool with the angle of the fence adjusted to other than 0°. When you need to use the angle guide under the above condition, be sure to adjust the depth of groove to get a proper depth.

The angle of the fence can be adjusted between 0° and 90° (positive stops at 0°, 45° and 90°). To adjust the angle, loosen the lock lever and tilt the fence until the pointer points to the desired graduation on the angle scale. Then tighten the lock lever to secure the fence. When the fence is set at 90°, both the distance from the center of the blade thickness to the fence and the distance from the center of the blade thickness to the bottom of the base are 10 mm.

#### Set plate (Fig. 7 & 8)

Use the set plate as shown in Fig. 7 & 8 when cutting slots in thin workpieces.

#### Switch action (Fig. 9)

##### ⚠ CAUTION:

- Before installing the battery cartridge into the tool, always check to see that the slide switch actuates properly and returns to the "OFF" position when the rear of the slide switch is depressed.
- Switch can be locked in "ON" position for ease of operator comfort during extended use. Apply caution when locking tool in "ON" position and maintain firm grasp on tool.

To start the tool, slide the slide switch toward the "I (ON)" position. For continuous operation, press the front of the slide switch to lock it.

To stop the tool, press the rear of the slide switch, then slide it toward the "O (OFF)" position.

#### Indication lamp with multi function (Fig. 10)

Indication lamps are located in two positions.

When the battery cartridge is inserted on the tool with the slide switch positioned in the "O (OFF)" position, the indication lamp flickers quickly for approximately one second. If it does not flicker so, the battery cartridge or indication lamp has broken.

##### – Overload protection

- When the tool is overloaded, the indication lamp lights up. When the load on the tool is reduced, the lamp goes out.
- If the tool continues to be overloaded and the indication lamp continues to light up for approximately two seconds, the tool stops. This prevents the motor and its related parts from being damaged.
- In this case, to start the tool again, move the slide switch to the "O (OFF)" position once and then to the "I (ON)" position.

##### – Battery cartridge replacing signal

- When the remaining battery capacity gets small, the indicator lamp lights up during operation earlier than enough capacity battery use.

##### – Accidental re-start preventive function

- Even if the battery cartridge is inserted on the tool with the slide switch in the "I (ON)" position, the tool does not start. At this time, the lamp flickers slowly and this shows that the accidental re-start preventive function is at work.
- To start the tool, first slide the slide switch toward the "O (OFF)" position and then slide it toward the "I (ON)" position.

## ASSEMBLY

##### ⚠ CAUTION:

- Always be sure that the tool is switched off and the battery cartridge is removed before carrying out any work on the tool.

## Removing or installing the blade (Fig. 11)

##### ⚠ CAUTION:

- When installing the plate joiner blade, mount the inner flange with the side marked "22" facing toward you.

To remove the blade, loosen the clamp screw and open the blade cover. Push the shaft lock and loosen the lock nut using the lock nut wrench. To install the blade, first mount the inner flange.

Then mount the blade and the lock nut. Securely tighten the lock nut using the lock nut wrench. Close the blade cover and tighten the clamp screw to secure the blade cover.

##### ⚠ CAUTION:

- Use only Makita lock nut wrench provided to remove or install the blade.
- Always check the depth of groove after replacing the blade. Readjust it if necessary.

## Dust bag (Fig. 12)

To attach the dust bag, fit it onto the dust nozzle. If the dust bag becomes an obstacle to your work, turn the dust nozzle to change the dust bag position.

When the dust bag is about half full, switch off and remove the battery cartridge. Remove the dust bag from the tool and pull the bag's fastener out. Empty the dust bag by tapping it lightly to remove as much of the dust as possible.

##### NOTE:

- If you connect a Makita vacuum cleaner to your plate joiner, more efficient and cleaner operations can be performed.

## OPERATION

### How to make joints

##### ⚠ WARNING:

- Always clamp the workpiece to the workbench before each operation. (Fig. 13 & 14)

#### Corner Joint (Fig. 15, 16 & 17)

#### T-Butt Joint (Fig. 18, 19 & 20)

#### Miter Joint (Fig. 21 & 22)

#### Frame Joint (Fig. 23 & 24)

#### Edge-To-Edge Joint (Fig. 25 & 26)

To make joints, proceed as follows:

1. Fit the two workpieces together as they will appear in the finished joint position.
2. Mark the center of the intended biscuit grooves on the workpiece using a pencil.

##### NOTE:

- The center of grooves should be at least 50 mm from the outer edge of the workpieces.
  - Allow 100 mm – 150 mm between grooves in multiple biscuit application.
3. **For Corner Joint and T-Butt Joint only**  
Clamp the vertical workpiece to the workbench.  
**For Miter Joint only**  
Clamp one workpiece to the workbench with the mitered edge facing up.  
**For Frame Joint and Edge-To-Edge Joint only**  
Clamp one workpiece to the workbench.
  4. Set the depth of groove according to the size of biscuit to be used. Refer to the table in the "Adjusting the depth of groove" section.

5. Adjust the angle guide height so that the blade is centered in the board thickness.
6. Align the center mark on the base with the pencil line on the workpiece.
7. Switch on the tool and gently push it forward to extend the blade into the workpiece.
8. Gently return the tool to the original position after the adjusting screw reaches the stopper.
9. **For Corner Joint and T-Butt Joint only**  
Clamp the horizontal workpiece to the workbench.  
**For Miter Joint only**  
Clamp the other workpiece to the workbench with the mitered edge facing up.  
**For Frame Joint and Edge-To-Edge Joint only**  
Clamp the other workpiece to the workbench.
10. **For Corner Joint only**  
Place the tool on the workpiece so that the blade is facing down.  
**For T-Butt Joint only**  
Remove the angle guide from the tool. Place the tool on the workpiece so that the blade is facing down.
11. Repeat the steps 6 – 8 to groove in the horizontal or the other workpiece.

If you do not need to center the blade in the board thickness, proceed as follows:

**For Corner Joint, Miter Joint, Frame Joint and Edge-To-Edge Joint only**

- Remove the angle guide from the tool. Set the fence at 90° for Corner Joint, Frame Joint and Edge-To-Edge Joint or at 45° for Miter Joint.
- Follow steps 1 – 11 excluding steps 5 and 10 described above.

**For T-Butt Joint only**

- Fit the two workpieces together as they will appear in the finished joint position.
- Lay the vertical workpiece on the horizontal one. Clamp both workpieces to the workbench.
- Remove the angle guide from the tool.
- Follow the steps 2, 4, 6, 7, 8 and 11 described above.

**MAINTENANCE**

**⚠ CAUTION:**

- Always be sure that the tool is switched off and the battery cartridge is removed before attempting to perform inspection or maintenance.
- Never use gasoline, benzine, thinner, alcohol or the like. Discoloration, deformation or cracks may result.

The tool and its air vents have to be kept clean. Regularly clean the tool's air vents or whenever the vents start to become obstructed. (Fig. 27)

**Replacing carbon brushes**

Remove and check the carbon brushes regularly. Replace when they wear down to the limit mark. Keep the carbon brushes clean and free to slip in the holders. Both carbon brushes should be replaced at the same time. Use only identical carbon brushes. (Fig. 28)

Insert the top end of slotted bit screwdriver into the notch in the tool and remove the holder cap cover by lifting it up. (Fig. 29)

Use a screwdriver to remove the brush holder caps. Take out the worn carbon brushes, insert the new ones and secure the brush holder caps. (Fig. 30)

Reinstall the holder cap cover on the tool.

To maintain product SAFETY and RELIABILITY, repairs, any other maintenance or adjustment should be performed by Makita Authorized Service Centers, always using Makita replacement parts.

**OPTIONAL ACCESSORIES**

**⚠ CAUTION:**

- These accessories or attachments are recommended for use with your Makita tool specified in this manual. The use of any other accessories or attachments might present a risk of injury to persons. Only use accessory or attachment for its stated purpose.

If you need any assistance for more details regarding these accessories, ask your local Makita Service Center.

- Angle guide
- Dust bag
- Set plate
- Lock nut wrench
- Plate joiner blades
- Various type of Makita genuine batteries and chargers

**NOTE:**

- Some items in the list may be included in the tool package as standard accessories. They may differ from country to country.

ENG905-1

**Noise**

The typical A-weighted noise level determined according to EN60745:

**Model BPJ140**

Sound pressure level ( $L_{pA}$ ): 73 dB (A)  
Uncertainty (K): 3 dB (A)

The noise level under working may exceed 80 dB (A).

**Model BPJ180**

Sound pressure level ( $L_{pA}$ ): 74 dB (A)  
Uncertainty (K): 3 dB (A)

The noise level under working may exceed 80 dB (A).

**Wear ear protection**

ENG900-1

**Vibration**

The vibration total value (tri-axial vector sum) determined according to EN60745:

Work mode: cutting grooves in MDF  
Vibration emission ( $a_h$ ): 2.5 m/s<sup>2</sup> or less  
Uncertainty (K): 1.5 m/s<sup>2</sup>

ENG901-1

- The declared vibration emission value has been measured in accordance with the standard test method and may be used for comparing one tool with another.
- The declared vibration emission value may also be used in a preliminary assessment of exposure.

**⚠ WARNING:**

- The vibration emission during actual use of the power tool can differ from the declared emission value depending on the ways in which the tool is used.
- Be sure to identify safety measures to protect the operator that are based on an estimation of exposure in the actual conditions of use (taking account of all parts of the operating cycle such as the times when the tool is switched off and when it is running idle in addition to the trigger time).

ENH101-15

**For European countries only**

**EC Declaration of Conformity**

**We Makita Corporation as the responsible manufacturer declare that the following Makita machine(s):**

Designation of Machine:

Cordless Plate Joiner

Model No./ Type: BPJ140, BPJ180

are of series production and

**Conforms to the following European Directives:**

2006/42/EC

And are manufactured in accordance with the following standards or standardised documents:

EN60745

The technical documentation is kept by our authorised representative in Europe who is:

Makita International Europe Ltd.

Michigan Drive, Tongwell,

Milton Keynes, Bucks MK15 8JD, England

11.7.2011



Tomoyasu Kato  
Director

Makita Corporation  
3-11-8, Sumiyoshi-cho,  
Anjo, Aichi, 446-8502, JAPAN