



ROUGH TERRAIN FORK LIFT | 930/940/950

Gross power: 74 hp | Lift capacity: 6,000 - 10,000 lb | Lift height: 15'-22'



PRODUCTIVITY AND PERFORMANCE

WHEN YOU'RE ON-SITE, PRODUCTIVITY AND PERFORMANCE ARE NATURALLY YOUR PRIMARY CONCERNS. THE LATEST JCB ROUGH TERRAIN FORKLIFTS OFFER PLENTY OF FEATURES DESIGNED TO ENSURE BOTH.

Engine and hydraulics.

The 4.4-liter JCB EcoMAX T4 Final-compliant engine produces its peak power (74 hp) and torque (295 lb-ft) at engine speeds as low as 1,200 RPM for great responsiveness.

A fixed geometry turbo further enhances performance at low engine speeds for improved power and tractive effort.



Our new larger high-flow hydraulic pump translates power into efficient lifting for increased productivity, and faster cycle times.



PRODUCTIVITY AND PERFORMANCE

Moving with the times.

- 1 Model options comprise the 930 (6,000 lb lift capacity), 940 (8,000 lb lift capacity), 950 (10,000lb lift capacity).
- 2 You can fine-tune your RTFL to any application and terrain; there's a choice of large diameter traction or industrial tires; 48", 60" or 72" long pallet forks; as well as the option of 2WD or 4WD on the 930 and 940 models.
- 3 So that you can choose from a huge range of options to boost productivity, we offer an optional single or double acting mast auxiliary.
- 4 Choose from two different carriage options: 60" or 72" Industrial Class IIIB ITA, or 66" or 84" floating shaft carriage.



4

A smooth operation.

- 5 The left column-mounted powershuttle gives the operator fast and easy directional control.
- 6 As part of JCB's Vertical Integration Strategy, we build the engine, transmission, hydraulic rams and cab of every RTFL so that they'll work in perfect harmony. The end result is minimum compromise, optimum performance.
- 7 All-wheel servo braking provides smooth and responsive stopping power and comes standard on all models.



5



1



6



7

COMFORT AND EASE OF USE

TO ACHIEVE MAXIMUM PRODUCTIVITY, A ROUGH TERRAIN FORKLIFT OPERATOR NEEDS TO BE COMFORTABLE AND IN CONTROL. AS SUCH, WE'VE CREATED A WORKPLACE THAT GETS THE BEST FROM YOUR OPERATORS AND YOUR MACHINERY.

A great place to work.

For all-day productive comfort, we offer both suspension and air suspension seating options that can be adjusted to different operator requirements or tasks.

1 In-cab noise levels are reduced, partly due to our positioning of the exhaust system towards the rear of the machine.

2 Operators can see both sides of the mast and carriage easily thanks to the slimline outer mast section.

Excellent upward visibility is provided by a large roof screen; in fact, visibility all-around is excellent, courtesy of direct glazing, fold-back rear doors, a low hood, high cab mounting position, and large front and rear windshields.

3 Optional front and rear work lights provide ultimate all-around visibility.



The large, spacious cab of our new RTFLs boasts left and right grab handles with wide-opening fold back doors for easy access; standard-fit tinted glass which reflects 30% of the sun's energy; and a new 3-speed heater fan for improved demisting/de-icing of the windshield in cold weather.

COMFORT AND EASE OF USE

Quality design.

- 4 New laser-etched switches are backlit to aid recognition and night visibility, while our simple lever controls ensure total command of mast and auxiliary functions.
- 5 You can lift and place loads easier with the standard mast side-shift of 4 in. right or left.
- 6 A zero tail swing design means that when the rear tire of a JCB RTFL has cleared an obstacle on full turn, you can be safe in the knowledge that the rear counterweight will clear it, too. This means our machines are ideal for working in confined areas.
- 7 JCB RTFLs are sold all over the world, so we offer a choice of cab (with or without air conditioning) or canopy to suit different climates.
- 8 These machines come equipped with a simple, robust 4-speed synchromesh transmission that helps to achieve a top speed of 18 mph.



QUALITY/RELIABILITY/DURABILITY

WE BUILD OUR ROUGH TERRAIN FORKLIFTS TO GO THE DISTANCE NO MATTER HOW TOUGH THE TASK. THAT'S WHY WE USE STATE-OF-THE-ART MANUFACTURING TECHNIQUES, RUGGED MATERIALS AND INNOVATIVE DESIGN TO CREATE THE STRONGEST MACHINES POSSIBLE.

A comfortable operator.

- 1 Our hydraulic cylinders have friction-welded eye-ends for extra strength, plus all pivots use hardened pins.
- 2 The one-piece fully welded chassis maximizes strength and minimizes weight.
- 3 Axles on the RTFL are the same heavy-duty units we fit to our backhoe loaders and Loadalls.
- 4 A mast on one of our RTFLs is made from heavy-duty channel and I-section steel, while the heavy-duty chains and guide roller bearings are sealed for life.

By electrophoretically dipping the cab before applying paint, we give these machines highly effective long-term corrosion protection.



QUALITY/RELIABILITY/DURABILITY

The JCB approach.

- 1 Like every JCB machine, our RTFLs are put through a stringent testing program which includes prolonged high stress loading of the chassis, mast and other key components, as well as repeated transmission use over thousands of cycles.
- 2 We use state-of-the-art manufacturing processes like robot machining, precision paint technology and innovative assembly techniques to achieve the very highest levels of quality.
- 3 JCB engines are tried and trusted. We've built 200,000 DIESELMAX engines since 2004, and we've tested our new EcoMAX design for 110,000 hours in 70 different machines across the toughest applications and environments.

Hydraulic rams, cabs, axles, transmissions and engines are all JCB-built, so you can expect optimum reliability and performance.



A SOUND INVESTMENT

A JCB ROUGH TERRAIN FORKLIFT ISN'T JUST EFFICIENT TO USE – IT'S HUGEY EFFICIENT TO OWN AND OPERATE TOO. WE'VE DESIGNED THESE MACHINES TO GIVE YOU THE MAXIMUM POSSIBLE RETURN ON YOUR INVESTMENT, WITH GREAT FUEL EFFICIENCY AND LOW RUNNING COSTS ALL PART OF THE PACKAGE.

EcoMAX efficiency.

1 Our new 74 hp high-torque EcoMAX engine maximizes both productivity and efficiency.

These T4 Final-compliant RTFLs are products of our Efficient Design program and, as such, use up to 10% less fuel than our outgoing Tier 3 models.

2 Because its peak power and torque are produced at low engine speeds, EcoMAX provides fuel-efficient matching of transmission and hydraulics.

Returning your investment.

3 The new larger hydraulic pump efficiently transforms power into lifting force for fast cycle times and improved fuel economy.

4 Every 4WD RTFL can be changed to 2WD at the flick of a switch, reducing fuel consumption and tire wear whenever 4WD isn't required – during roading, for example.

JCB's EcoMAX engine design doesn't need exhaust aftertreatment, so costly heat-resistant lube oils or AdBlue are unnecessary; in turn, you save on servicing costs.



SERVICEABILITY

NOBODY LIKES DOWNTIME BUT MACHINE SERVICING IS, OF COURSE, UNAVOIDABLE. FORTUNATELY, OUR ROUGH TERRAIN FORKLIFTS ARE SO RUGGED THAT THEY REQUIRE LESS SERVICING THAN MOST, ENSURING MAXIMUM PRODUCTIVE UPTIME.

Simple servicing.

1 On a JCB RTFL, all daily checks can be carried out easily at ground level; grease points are all accessible from ground level too.

Gas-assisted cylinders make opening the hood easy, and the large wide service bay provides good access to two sides of the engine.

2 The air filter on these machines is easily accessible, and a single-element construction simplifies cleaning.

3 All of the filters (engine oil, fuel, transmission, hydraulic oil and air) are located close to each other for fast, simple servicing.

4 It's easy to get to the diesel tank on one of our new RTFLs, and it can be filled from ground level too. There's also an integral pre-filter in the filler neck for protection against dirty fuel.

5 Our hydraulic tank is easily accessible and can be filled from ground level.

Minimized downtime.

Although most Tier 4 FINAL engines require exhaust aftertreatment like a Diesel Particulate Filter (DPF) or SCR, EcoMAX doesn't; this means you don't need to worry about costly heat-resistant lube oils or AdBlue fluid level maintenance.

To keep our machines productive, we minimize downtime as much as possible; service intervals are therefore long.

JCB LiveLink telematics technology offers a whole range of benefits. Real-time data keeps you in complete control of your machine, allowing you to monitor and manage it remotely. You can also monitor any issues and get them resolved swiftly by your JCB dealer, thus boosting productivity throughout the working day.



SAFETY AND SECURITY

SAFETY IN THE WORKPLACE IS MORE IMPORTANT THAN EVER, AND OUR NEW ROUGH TERRAIN FORKLIFTS ARE BUILT WITH THIS IN MIND. OPERATORS, MACHINERY AND BYSTANDERS ALIKE ARE WELL-PROTECTED FROM HAZARDS.

A safer workplace.

- 1 Ergonomically positioned grab handles and two cab steps provide quick, easy and safe operator access with three points of contact at all times.
- 2 Hydraulic velocity fuse (HVF) on the rams guard against collapse in the event of a hose failure.
- 3 We fit our RTFLs with a reversing alarm as standard.
- 4 Our seat safety switch disables forward/reverse controls whenever the operator isn't seated.
- 5 All cabs on our RTFLs are FOPS (Falling Objects Protection System) certified, ensuring excellent operator protection at all times.
- 6 For even greater operator protection against falling debris, opt for our front-screen guard.

Security features.

- 7 A factory-fit JCB immobilizer can be either key or keypad-activated; it also automatically arms itself after a set period following engine shutdown. This technology helps to safeguard your machine.



JCB's LIVELINK telematics GPS tracking system provides real-time machine location data with Geofencing alerts; this allows you to track machine coverage and protect your investment.

LIVELINK, WORK SMARTER

LiveLink keeps track of each machine's efficiency, so you get the best value for money.



- Manage your fleet anywhere
- Drive down cost
- Improve productivity
- Fuel level and consumption*
- Customized reports by day / week / month

**For machines with electronic engine management system only*

LiveLink reports machine's exact location, movement and activity offering greater protection against theft.



- Pinpoint machine location
- 24/7 update on your phone/tablet
- Real-time curfew alerts
- Real-time geofence alerts
- Back-up battery
- Tow-away alert



LiveLink sends service alerts and diagnostic warnings to ensure your machine's maximum uptime.



- Machine health alerts
- Machine service alerts
- Accurate hours recorded
- Detailed machine history
- Maintenance planning

Machine Servicing Agreement

Peace of mind



Enhanced Dealer Support

JCB LiveLink

VALUE ADDED

WHATEVER YOU NEED AND WHEREVER YOU ARE, THE DEPENDABLE JCB DEALER NETWORK IS HERE TO MAKE SURE YOUR MACHINERY PERFORMS TO ITS FULL POTENTIAL.



1 JCB Technical Support Service provides instant access to factory expertise, day or night. JCB's Finance and Insurance teams are always on hand to provide fast, flexible, competitive quotes.

2 The global network of JCB Parts Centers is a model of efficiency. With 16 regional bases, we can deliver around 95 percent of all parts anywhere in the world within 24 hours. Our genuine JCB parts are designed to work in perfect harmony with your machine for optimum performance and productivity.



3 JCB Yellow Shield offers comprehensive extended warranties and service agreements, as well as service-only or repair and maintenance contracts. JCB maintenance teams offer competitive labor rates and no obligation quotes.



Note: JCB LiveLink and JCB Yellow Shield may not be available in your region, so please check with your local dealer.

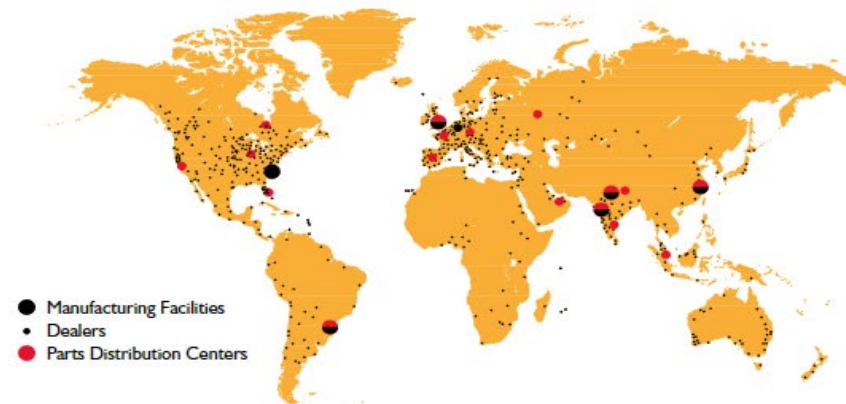

930/940/950 ROUGH TERRAIN FORK LIFT

SPECIFICATION

STATIC DIMENSIONS

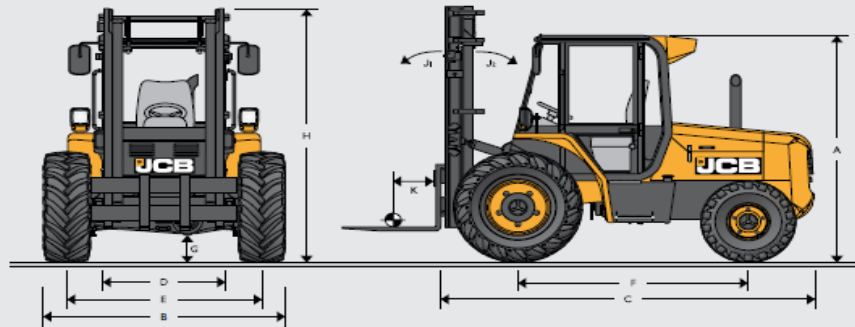

Machine model		930	940	950	
A	Overall cab height	ft-in	8-4	8-4	8-4
B	Overall width (over tires)	ft-in	7-2	7-2	7-2
C	Overall length to front carriage	ft-in	11-7	11-9	11-9
D	Inside width of cab	ft-in	3-6	3-6	3-6
E	Front track	ft-in	5-9	5-9	5-9
F	Wheel base	ft-in	6-9	7-2	7-2
G	Ground clearance	ft-in	0-10	0-10	0-10
H1	Mast tilt forwards	degree	18	18	22
H2	Mast tilt backwards	degree	10	10	10
J	Load center	ft-in	0-21	0-21	0-21

The above data is based on the following specification: Standard fork size 42 x 3 x 1 inch.

WEIGHT

Machine model		930	940	950
Machine weight with following mast				
15' 0" freelif	lb	13,985	15,190	-
22' 0" clearview	lb	14,495	15,750	17,295
22' 0" freelif	lb	14,600	18,810	-

The above data is based on the following specification: Standard fork size 42 x 3 x 1 inch.

TURN RADIUS AND GROUND LINE ANGLES

Machine model		930	940	950
Outside turn radius 2WD	ft-in	14-4.4	14-7.2	-
Outside turn radius 4WD	ft-in	14-3.3	16-1.7	16-1.7
Departure angle		53	53	53
Obstruction angle		51	51	51

The above data is based on the following specification: Standard fork size 42 x 3 x 1 inch.

ENGINE

Machine model	930/940/950	
Model	JCB ECOMAX TCAE-55	
Displacement	liters	4.4
Fuel	Diesel	
Cooling	Liquid	
Bore	in	4.05
Stroke	in	5.19
Gross power – ISO 14,396 @ 2000 rpm	hp (kW)	74 (55)
Gross torque – ISO 14,396 @ 1300 rpm	lb-ft	295
Emission certification	TIER IV FINAL	
Engine oil service intervals	500 hours	

TRANSMISSION

Machine model	930/940/950	
Manufacturer	JCB	
Type	Synchroshuttle	
Torque converter	11 inches	
Torque converter ratio	2.20:1	
Gears forward/reverse	4/4	
Gear selection	Manual	
Shuttle control - F/R	Power shuttle	
Travel speeds	mph	
Gear 1	3.2	
Gear 2	5.3	
Gear 3	10.1	
Gear 4	18.4	

For unbeatable drive power in all conditions, the JCB Synchro Shuttle combines a 4-speed, fully synchromesh gearbox with integral torque converter and electrically operated reversing shuttle for smooth gear changes on the move and fast cycle times. Column mounted electric switch effortlessly controls machine direction changes allowing operator to keep hands on steering wheel. Automotive style pedal layout and conventional H-pattern gear lever add to ease of operation. Travel speed 18mph. Front drive axle: JCB epicycle hub reduction drive axle with Max-Trac torque proportioning differentials. Rear steer axles: JCB manufacture with hydrostatic power steering. Steer shock valve as standard. 4WD versions with epicyclic hub reduction and Max-Trac torque proportioning differentials.

TIRES

Machine model	930/940/950	
Standard tires	15.5-25	
Front 2WD	15.5-25 (12 ply)	
Rear 2WD	12.5/80-18 (10 ply)	
Front 4WD	15.5-25 (12 ply)	
Rear 4WD	14-17.5 (10 ply)	

SPECIFICATION

930/940/950 ROUGH TERRAIN FORK LIFT

ELECTRICAL SYSTEM

Machine model	930/940/950		
System voltage	Volt	12	
Alternator output	Amp hour	95	
Battery capacity	Amp hour	120	

SERVICE CAPACITIES

Machine model	930/940/950		
Fuel tank	gal	19.3	
Hydraulic tank	gal	13.1	
Engine oil sump	gal	2.6	
Transmission oil system	gal	4	
Engine coolant system	gal	3.7	

BRAKES	Service brakes: Hydraulically activated, servo assisted self-adjusting, oil-immersed in-board multi-disc type in front axle standard on 930/940/950. Parking brake: Hand operated disc brake on output of gearbox.
---------------	---

HYDRAULICS	Single gear pump with steer priority valve, suction strainer and filter. Operating system pressure: 3,205 psi, flow 20 gpm. Pipe burst protection on mast hydraulics.
-------------------	---

MASTS AND CARRIAGES	Clearview masts manufactured from channel and I-section steel. Heavy-duty mast chains. Guide roller bearings are sealed for life. Industrial class IIIB carriage, or floating shaft carriage available on various masts. Adjustable right hand tilt ram. Freelift masts are ideal for applications with height restrictions; the carriage moves the height of the mast before any extension. Clearview mast sections extend simultaneously and are best used in open spaces with no overhead limitations. Mast side-shift is standard - 4 in (Right/Left)
----------------------------	---

OPERATOR MODULE	Safety quiet cab or canopy, FOPS standard (falling object protective structure) to ANSI B56.6 - 1978. Cab: Resiliently mounted, two door access, level floor with mat, safety glass all around with laminated roof window. Features include: Suspension cloth/vinyl seat, rear view mirror and 2 speed heater/demister. Front/Rear screen wiper and washer, horn. Handbook. Instruments for hour meter battery charge. Audible/Visual warning system for alternator charge, coolant temperature, engine oil pressure, blocked air filter, transmission oil pressure and temperature. Warning lights for: park brake on. Hydraulic control levers, gear lever, park brake, forward/reverse lever, 4WD disconnect, throttle, brake, and transmission disconnect button. Canopy: As above but with no glazing (screen wiper and heater/screen demister not applicable), and rear fenders are optional.
------------------------	---

OPTIONS AND ATTACHMENTS	Wheel and tire sets. Air suspension seat. Roof screen washer/wiper. Flashing roof beacon. Fire extinguisher. Cab exterior mirrors. Front screen guard. Optional rear fenders. Reversing lights. Engine fan guard kit. Front and rear cab lights. Immobilizer. Roadlight.
--------------------------------	--

PERFORMANCE DIMENSIONS - 930

Description of mast	Overall lowered height (in)	Overall height raised (in)	Freelift (in)	Max fork height (in)	Capacity at full height (lb)	Mast raise/lower speed (ft/min)
15' FL - 66" Shaft Carriage	98.5	215.3	62.9	180.5	6,000	1.0 / 1.49
15' FL - 84" Shaft Carriage	98.5	215.3	62.9	180.5	6,000	1.0 / 1.49
15' FL - 60" ITA Carriage	98.5	215.3	64.5	182.0	6,000	1.0 / 1.49
15' FL - 72" ITA Carriage	98.5	215.3	64.5	182.0	6,000	1.0 / 1.49
22' FL - 66" Shaft Carriage	126.5	299.3	91	180.5	2,500	1.0 / 1.49
22' FL - 84" Shaft Carriage	126.5	299.3	91	180.5	2,500	1.0 / 1.49
22' FL - 60" ITA Carriage	126.5	299.3	92.5	266	2,500	1.0 / 1.49
22' FL - 72" ITA Carriage	126.5	299.3	92.5	266	2,500	1.0 / 1.49
22' CV - 66" Shaft Carriage	126.5	301.8	-	264.5	2,500	1.64 / 1.75
22' CV - 84" Shaft Carriage	126.5	301.8	-	264.5	2,500	1.64 / 1.75
22' CV - 60" ITA Carriage	126.5	301.8	-	266	2,500	1.64 / 1.75
22' CV - 72" ITA Carriage	126.5	301.8	-	266	2,500	1.64 / 1.75

PERFORMANCE DIMENSIONS - 940

Description of mast	Overall lowered height (in)	Overall height raised (in)	Freelift (in)	Max fork height (in)	Capacity at full height (lb)	Mast raise/lower speed (ft/min)
15' FL - 66" Shaft Carriage	98.5	215.3	62.9	180.5	8,000	1.48 / 1.63
15' FL - 84" Shaft Carriage	98.5	215.3	62.9	180.5	8,000	1.48 / 1.63
15' FL - 60" ITA Carriage	98.5	215.3	64.5	182	8,000	1.48 / 1.63
15' FL - 72" ITA Carriage	98.5	215.3	64.5	182	8,000	1.48 / 1.63
22' FL - 66" Shaft Carriage	126.5	299.3	91	264.5	3,500	1.48 / 1.63
22' FL - 84" Shaft Carriage	126.5	299.3	91	264.5	3,500	1.48 / 1.63
22' FL - 60" ITA Carriage	126.5	299.3	92.5	266	3,500	1.48 / 1.63
22' FL - 72" ITA Carriage	126.5	299.3	92.5	266	3,500	1.48 / 1.63
22' CV - 66" Shaft Carriage	126.5	301.8	-	264.5	3,500	1.64 / 1.75
22' CV - 84" Shaft Carriage	126.5	301.8	-	264.5	3,500	1.64 / 1.75
22' CV - 60" ITA Carriage	126.5	301.8	-	266	3,500	1.64 / 1.75
22' CV - 72" ITA Carriage	126.5	301.8	-	266	3,500	1.64 / 1.75

PERFORMANCE DIMENSIONS - 950

Description of mast	Overall lowered height (in)	Overall height raised (in)	Freelift (in)	Max fork height (in)	Capacity at full height (lb)	Mast raise/lower speed (ft/min)
15' FL - 66" Shaft Carriage	103.5	215.3	62.9	180.5	10,000	1.48 / 1.63
15' FL - 84" Shaft Carriage	103.5	215.3	62.9	180.5	10,000	1.48 / 1.63
15' FL - 60" ITA Carriage	103.5	215.3	64.5	182	10,000	1.48 / 1.63
15' FL - 72" ITA Carriage	103.5	215.3	64.5	182	10,000	1.48 / 1.63
22' FL - 66" Shaft Carriage	131.5	299.3	91.0	265.5	6,500	1.48 / 1.63
22' FL - 84" Shaft Carriage	131.5	299.3	91.0	265.5	6,500	1.48 / 1.63
22' FL - 60" ITA Carriage	131.5	299.3	92.5	266.0	6,500	1.48 / 1.63
22' FL - 72" ITA Carriage	131.5	299.3	92.5	266.0	6,500	1.48 / 1.63
22' CV - 66" Shaft Carriage	126.5	301.8	-	264.5	6,500	1.64 / 1.75
22' CV - 84" Shaft Carriage	126.5	301.8	-	264.5	6,500	1.64 / 1.75
22' CV - 60" ITA Carriage	126.5	301.8	-	266.0	6,500	1.64 / 1.75
22' CV - 72" ITA Carriage	126.5	301.8	-	266.0	6,500	1.64 / 1.75





ONE COMPANY, MORE THAN 300 MACHINES.

Your nearest JCB dealer

ROUGH TERRAIN FORK LIFT 930/940/950

Gross power: 74 hp Lift capacity: 6,000 -10,000 lb Lift height: 15'-22'

JCB North America

2000 Bamford Blvd., Pooler, Georgia, 31322 Tel: (912) 447-2000

Download the very latest information on this product range at www.jcb.com

JCB inc. All rights reserved. No part of this publication may be reproduced, stored in a retrieval system, or transmitted in any form or by any other means, electronic, mechanical, photocopying or otherwise, without prior permission from JCB inc. All references in this publication to operating weights, sizes, capacities and other performance measurements are provided for guidance only and may vary dependent upon the exact specification of machine. They should not therefore be relied upon in relation to suitability for a particular application. Guidance and advice should always be sought from your JCB Dealer. JCB reserves the right to change specifications without notice. Illustrations and specifications shown may include optional equipment and accessories. The JCB logo is a registered trademark of J.C. Bamford Excavators Ltd.

JCBNA
 @JCBNA
 JCBNORTHAMERICA
 JCBNA

02/20 Issue 1 DWUSA 4849

