

OPERATING DIMENSIONS	
Working Height Maximum (Indoor)	16.02 m
Working Height Maximum (Outdoor)	8.55 m
(A) Platform Height Maximum (Indoor)	14.02 m
Platform Height Maximum (Outdoor)	6.55 m
(B) Platform Height - Stowed	1.62 m
(C) Platform Length – Outside, Extended	4.10 m
Slide out Platform Extension Deck	1.22 m
(D) Platform Width - outside	1.35 m
Guardrail Height	1.10 m
Toeboard Height	0.15 m
(E) Height – Stowed: Folding Rails	2.74 m
Rails Lowered	1.97 m
(F) Length – Stowed	3.14 m
- Extended	4.36 m
(G) Width	1.40 m
(H) Wheelbase	2.46 m
(I) Ground Clearance – Centre	15 cm
- with pothole guards deployed	2 cm
PRODUCTIVITY	
Max Platform Occupancy (Indoor/outdoor)	3/3
Lift Capacity	350 kg
Lift Capacity – Extension Deck	136 kg
Drive Height	Full Height
Drive Speed - stowed	2.8 mph
Drive Speed - raised	0.5 mph
Gradeability – stowed**	25%
Turning Radius - inside	30 cm
Turning Radius - outside	3.12 m
Raise / lower speed	92/58 sec
Controls	Proportional
Drive	Dual front wheel, ac electric
Brakes	Dual front wheel, electric
Tyres solid non-marking	38 x 13 x 28 cm
Ground pressure (tyres)	1535 kPa
POWER, SOUND AND WEIGHT	
Power Source	24 V DC, 300 Ah (four 12V, 150 Ah batteries in parallel series)
Hydraulic System Capacity	28.4 L
Sound Pressure Level (ground workstation)	< 70 dB(A)
Sound Pressure Level (platform workstation)	< 70 dB(A)
Vibration	<2 .5 m/s ²
Weight	3700 kg

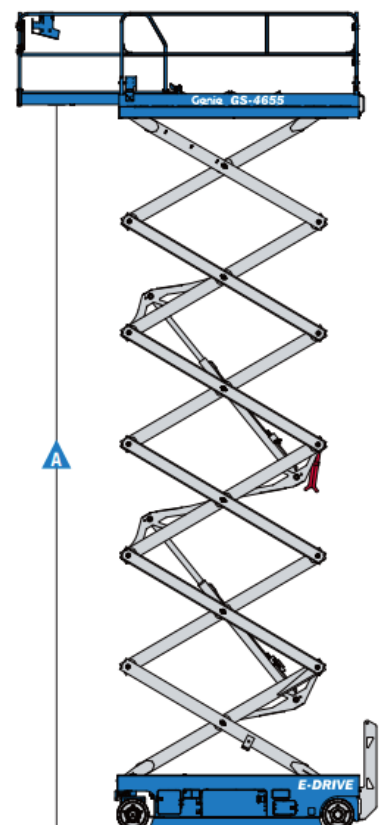
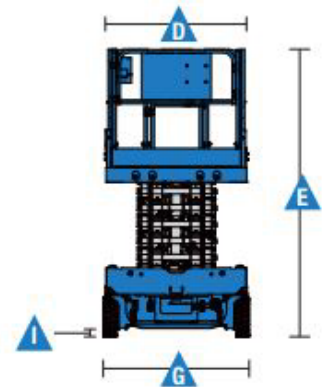
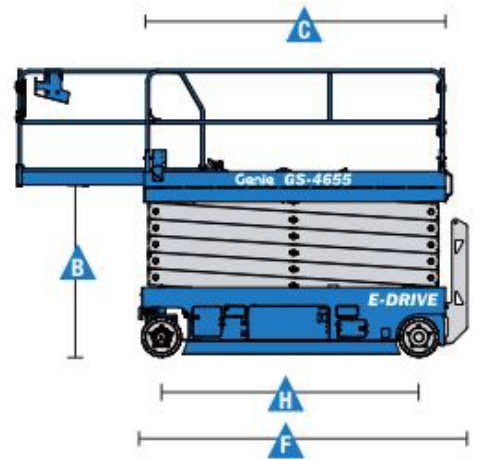

Standard Features

Measurements

- 16.02 m (52 ft) working height
- 350 kg (770 lb) max. lift capacity

Productivity

- Drive at full height
- Folding rails with half-height swing gate
- Smart link™ control system (joystick, proportional lift & drive, user-friendly diagnostics)
- Rear recessed charger receptacle
- Platform control with battery charge indicator
- Platform control guard
- On-board diagnostic system
- AC power to platform
- Lanyard attachment points
- Manual platform lowering valve
- Emergency stop at both platform and ground controls
- Dual front wheel electric brakes
- Manual and electric brake release
- Swing-out component trays
- Side forklift pockets
- Pothole guards
- Tilt level sensor with audible alarm
- Descent alarm
- Motion alarm
- Flashing LED beacons
- Electronic horn
- Hour meter

Power

- 24 V DC battery pack
- Universal 20amp smart charger

Platform

- 2.88 m x 1.35 m steel platform with diamond plate platform floor
- 1.20 m extension deck

Power

- 24 V DC, 300 Ah (four 12 V 150 Ah batteries in parallel series)

Drive

- Dual front wheel AC electric drive

Tyres

- Solid non-marking

Options & Accessories

Productivity options

- Air line to platform
- Power to platform: plug, socket, with optional Residual-current Circuit Breaker with Overcurrent protection
- Biodegradable hydraulic oil
- Automotive-style horn

Power Options

- AGM maintenance-free batteries

