

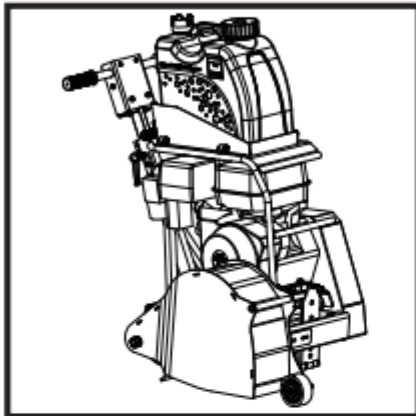

# BELLE DUO 350X

870/30013/0  
05/18



Ⓒ Operators Manual

4

• Spare Parts Book

14

**EC DECLARATION OF CONFORMITY / DECLARATION CE DE CONFORMITE / DECLARACIÓN DE CONFORMIDAD CE / DECLARAÇÃO CE DE CONFORMIDADE / EG-VERKLARING VAN OVEREENSTEMMING / EF OVERENSSTEMMELSESERKLÆRING**

- (GB)** We, Belle Group Sheen UK, Sheen, Nr. Buxton, Derbyshire, SK17 0EU, GB, hereby certify that if the product described within this certificate is bought from an authorised Belle Group dealer within the EEC, it conforms to the following EEC directives: 2006/42/CE (This directive replaces directive 98/37/EC), Electromagnetic Compatibility Directive 2004/108/CE (as amended by 89/336/EEC, 92/31/EEC & 93/68 EEC), The Waste Electrical and Electronic Equipment (WEEE) 2002/96/CE, the low voltage directive 2006/95/CE, BS EN ISO 12100-1:2003 Safety of machinery and associated harmonised standards, where applicable. Noise emissions conform to directives 2000/14/EC Annex V & 2005/88/EC  
*Noise Technical files are held by Ray Neilson at the Belle group Head Office address which is stated above.*
- (F)** Nous soussignés, Belle Group Sheen UK, Sheen, Nr. Buxton, Derbyshire, SK17 0EU, GB, certifions que si le produit décrit dans ce certificat est acheté chez un distributeur autorisé Belle Group au sein de la CEE, il est conforme aux normes CEE ci-après: 2006/42/CE (Cette norme remplace la norme 98/37/CE), Norme compatible pour l'électromagnétisme 2004/108/CE (modifié par 89/336/EEC, 92/31/EEC & 93/68 EEC). Les déchets électriques, et d'équipement électronique 2002/96/CE, caractéristiques basse tension 2006/95/CE, BS EN ISO 12100-1:2003 Norme de sécurité des machines et des critères associés et configurés, si applicable. Les émissions de bruit sont conformes à la directive 2000/14/EC Annexe V et 2005/88/EC.  
*Bruit des fichiers techniques sont détenues par Ray Neilson à l'adresse du groupe Belle Siège qui est indiqué ci-dessus.*
- (E)** La Sociedad, Belle Group Sheen UK, Sheen, Nr. Buxton, Derbyshire, SK 17 0EU, GB, por el presente documento certifica que si el producto descrito en este certificado es comprado a un distribuidor autorizado de Belle Group en la CEE, este es conforme a las siguientes directivas: 2006/42/CE de la CEE (Esta directiva sustituye a la Directiva 98/37/CE), Directiva 2004/108/CE sobre Compatibilidad Electromagnética (según enmiendas 89/336/EEC, 92/31/EEC & 93/68 EEC). Los residuos eléctricos y electrónicos (RAEE) 2002/96/CE, Directiva sobre Bajo Voltaje 2006/95/CE, BS EN ISO 12100-1:2003 de Seguridad de Maquinaria y Niveles armonizados estándares asociados donde sean aplicables. Emisión de Ruidos conforme a la Directiva 2000/14/CE Anexo V y 2005/88/EC.  
*Archivos de ruido técnicos están en manos de Ray Neilson en la dirección del grupo Belle Sede de la que se ha dicho.*
- (P)** O signatário, Belle Group Sheen UK, Sheen, Nr. Buxton, Derbyshire, SK 0EU, GB, pelo presente, declara que se o produto descrito neste certificado foi adquirido a um distribuidor autorizado do Belle Group em qualquer país da UE, está em conformidade com o estabelecido nas seguintes directivas comunitárias: 2006/42/CE (Esta directiva substitui a Directiva 98/37/EC), Directiva de Compatibilidade Electromagnética 2004/108/CE (conforme corrigido pelas 89/336/EEC, 92/31/EEC & 93/68 EEC). O Eléctrico de Desperdício e Equipamento Electrónico (DEEE) 2002/96/CE, a directiva de baixa voltagem 2006/95/CE, BS EN ISO 12100-1:2003 Segurança da maquinaria e às normas harmonizadas afins se aplicáveis. As emissões de ruído respeitam e estão dentro das directivas para máquinas 2000/14/EC Anexo V & 2005/88/EC  
*Arquivos de ruído técnicos são detidos por Ray Neilson no endereço Escritório Belle grupo Cabeça que é dito acima.*
- (NL)** Ondergetekende, Belle Group Sheen UK, Sheen, Nr. Buxton, Derbyshire, SK17 0EU, GB, verklaren hierbij dat als het product zoals beschreven in dit certificaat is gekocht van een erkende Belle Group dealer binnen de EEG, het voldoet aan de volgende EEG richtlijnen: 2006/42/CE (Deze richtlijn vervangt Richtlijn 98/37/EC), Electromagnetische Compatibility Richtlijn 2004/108/CE (geamendeerd door 89/336/EEC, 92/31/EEC & 93/68 EEC). De afgedankte elektrische en elektronische apparatuur (AEEA) 2002/96/CE, de Laagspannings Richtlijn 2006/95/CE, BS EN ISO 12100-1:2003 Veiligheid van Machines en hieraan gekoppelde geharmoniseerde Standaarden, waar deze van toepassing is. Geluidshinder te voldoen aan de richtlijnen 2000/14/EG en 2005/88/EG bijlage V.  
*Lawaai Technische dossiers zijn in handen van Ray Neilson op de Belle groep hoofdkantoor adres, dat staat boven.*
- (DK)** Vi, Belle Group Sheen UK, Sheen, Nr. Buxton, Derbyshire, SK17 0EU, GB, erklærer hermed, at hvis det i dette certifikat beskrevne produkt er købt hos en autoriseret Belle Group forhandler i EU, er det i overensstemmelse med følgende EØF-direktiver: 2006/42/CE (Dette direktiv erstatter direktiv 98/37/EF), 2004/108/EØF (som ændret ved 89/336/EEC, 92/31/EØF & 93/68 EØF), Affald af elektrisk og elektronisk udstyr (WEEE) 2002/96/CE, lavspændingsdirektivet 2006/95/CE, BS EN ISO 12100-1:2003 Maskinsikkerhed og tilhørende harmoniserede standarder, hvor det er relevant. Støjemission i overensstemmelse med direktiverne 2000/14/EF bilag V og 2005/88/EF.  
*Støj Tekniske filer er i besiddelse af Ray Neilson på Belle-gruppen hovedkontoret adresse, som er nævnt ovenfor.*

PRODUCT TYPE .....	TYPE DE PRODUIT.....	TIPO DE PRODUCTO .....
MODEL.....	MODELE.....	MODELO .....
SERIAL No.....	Nº DE SERIE.....	Nº DE SERIE.....
DATE OF MANUFACTURE.....	DATE DE FABRICATION .....	FECHA DE FABRICACIÓN.....
SOUND POWER LEVEL MEASURED / .....	NIVEAU DE PUISSANCE SONORE MESUREE / .....	NIVEL DE POTENCIA ACÚSTICA MEDIDO / .....
.....(GUARANTEED)	.....(GARANTIE)	.....(GARANTIZADO)
WEIGHT.....	POIDS.....	PESO.....
TIPO DE PRODUCTO.....	PRODUCTTYPE.....	PRODUKTTYPE.....
MODELO.....	MODEL.....	MODEL.....
NO. DE SÉRIE.....	SERIENUMMER.....	SERIENR.....
DATA DE FABRIC.....	FABRICAGEDATUM.....	FREMSTILLINGSDATO.....
NIVEL DE POTENCIA DE SOM MEDIDO / .....	GEMETEN GELUIDSSTERKTENIVEAU / .....	LYDEFEKTNIVEAU MÅLT / .....
.....(GARANTIDO)	.....(GEGARANDEERD)	.....(GARANTERET)
PESO.....	GEWICHT.....	VÆGT.....

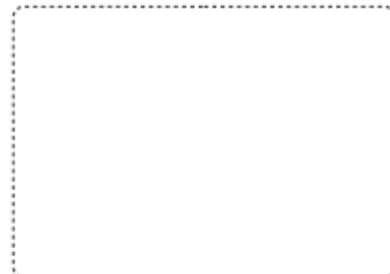

Signed by:  
Signature:  
Medido por:  
Assinado por:  
Getekend door:  
Underskrevet af:  
  
**Ray Neilson**

**Managing Director - On behalf of BELLE GROUP (SHEEN) UK.**  
**Le Directeur Général - Pour le compte de la SOCIETE BELLE GROUP (SHEEN) UK.**  
**Director Gerente - En nombre de BELLE GROUP (SHEEN) UK.**  
**Director-Geral - Em nome de BELLE GROUP (SHEEN) UK.**  
**Algemeen Directeur - Namens BELLE GROUP (SHEEN) UK.**  
**Administrerende direktør - På vegne af BELLE GROUP (SHEEN) UK.**

Place of Declaration - Sheen, Nr. Buxton, Derbyshire, SK17 0EU, UK  
Lieu de déclaration - Sheen, Nr. Buxton, Derbyshire, SK17 0EU, UK  
Declaración hecha en - Sheen, Nr. Buxton, Derbyshire, SK17 0EU, UK  
Lugar de Declaração - Sheen, Nr. Buxton, Derbyshire, SK17 0EU, UK  
Plaats van de Verklaring - Sheen, Nr. Buxton, Derbyshire, SK17 0EU, UK  
Sted i erklæring - Sheen, Nr. Buxton, Derbyshire, SK17 0EU, UK

Date of Declaration - 2015 .....

Date de déclaration - 2015 .....

Fecha de la declaración - 2015 .....

Data da Declaração - 2015 .....

Datum van de verklaring - 2015 .....

Dato for erklæringen - 2015 .....

**EGKONFORMITÄTSERKLÄRUNG / DICHIARAZIONE CE DI CONFORMITÀ / EG-VERKLARING VAN OVEREENSTEMMING / EC SAMSVARERKLÆRING / EY-YHDENMUKAISUUSILMOITUS / DEKLARACJA ZGODNOSCI Z PRZEPISAMI UE**

**(D)** Wir, Belle Group Sheen UK, Sheen, Nr. Buxton, Derbyshire, SK17 0EU, GB, bestätige hiermit, dass, wenn das Produkt innerhalb dieser Bescheinigung ist von einem gekauft zugelassen Belle Group-Händler innerhalb der EWG, so entspricht sie den folgenden EG-Richtlinien: 2006/42/CE (Diese Richtlinie ersetzt die Richtlinie 98/37/EG), elektromagnetische Kompatibilität Richtlinie 2004/108/EG (geändert durch 89/336/EWG, 92/31/EWG und 93/68 EWG), Die Elektro-und Elektronik-Altergeräte (WEEE) 2002/96/CE, der Niederspannungs-Richtlinie 2006/95/CE, BS EN ISO 12100-1:2003 Sicherheit von Maschinen und der damit verbundenen harmonisierten Normen, sofern zutreffend.  
**Lärm Technische Dateien werden von Ray Neilson im Belle Group Head Office Adresse, die oben angegeben stoff.**

**(I)** Il Gruppo Belle Sheen UK, Sheen, Nr. Buxton, Derbyshire, SK17 0EU, GB, certifica che, se il prodotto descritto nel presente certificato viene acquistato da un rivenditore autorizzato Belle gruppo all'interno della CEE, è conforme alle seguenti direttive CEE: 2006/42/CE (presente direttiva sostituisce la direttiva 98/37/CE), elettromagnetica compatibilità con la direttiva 2004/108/CE (modificata dalla 89/336/CEE, 92/31/CEE e 93/68 CEE), L'Elettrodomestico di Spreco e l'Apparecchiatura Elettronica (WEEE) 2002/96/CE, la direttiva bassa tensione 2006/95/CE, BS EN ISO 12100-1:2003 Sicurezza del macchinario e le relative norme armonizzate, se del caso.  
**File rumore tecnici sono tenuti da Ray Neilson all'indirizzo dell'Ufficio gruppo Belle Sede che è riportata sopra.**

**(S)** Undertecknade, Belle Group Sheen UK, Sheen, Nr Buxton, Derbyshire, SK17 0EU, Storbritannien, intygar härmed att om den produkt som beskrivs i detta intyg är köpt från en auktoriserad Belle-återförsäljare inom EEG, överensstämmer med följande EEG-direktiv: 2006/42/CE (Detta direktiv ersätter direktiv 98/37/EG), Elektromagnetisk kompatibilitet 2004/108/CE (ändrat genom direktiv 89/336/EEG, 92/31/EEG och 93/68 EEG), Avfall från elektriska och elektroniska produkter (WEEE) 2002/96/CE, lågspanningsdirektivet 2006/95/CE, BS EN ISO 12100-1:2003 Maskinsäkerhet och tillhörande harmoniserade standarder, i förekommande fall.  
**Buller Tekniska filer innehas av Ray Neilson på Belle Group Huvudkontor adress som anges ovan.**

**(NO)** Vi, Belle Group Sheen UK, Sheen, Nr Buxton, Derbyshire, SK17 0EU, GB, herved bekrefter at hvis produktet er beskrevet i dette sertifikatet er kjøpt fra en autorisert Belle Group forhandler innenfor EØS, følger det med til følgende EEC direktiver: 2006/42/CE (Dette direktivet erstatter direktiv 98/37/EF), Det elektromagnetisk kompatibilitets-direktiv 2004/108/CE (endret ved 89/336/EEC, 92/31/EEC og 93/68 EEC), Avfallet Elektrisk og Elektronisk Utstyr (WEEE) 2002/96/CE, Lavspenningsdirektiv 2006/95/CE, BS EN ISO 12100-1:2003 Sikkerhet av maskiner og tilhørende harmoniserte standarder, der dette er aktuelt.  
**Støy Tekniske filene holdes av Ray Neilson på Belle gruppen hovedkontor adresse som er angitt ovenfor.**

**(SF)** Me, Belle Group Sheen UK, Sheen, Nr. Buxton, Derbyshire, SK17 0EU, GB, todistaa, että jos tuote on kuvattu tämän todistuksen ostetaan valtuutetun Belle jälleenmyyjä ETY: n sisällä, se täyttää seuraavat EY-direktiivihin: 2006/42/EY (tällä direktiivillä korvataan direktiivi 98/37/EY), sähkömagneettinen yhteensopivuutta direktiivin 2004/108/CE (muutettuna 89/336/EY, 92/31/EY ja 93/68 EY). Tuhlaa Sähkö ja Sähköinen Varusteet (WEEE) 2002/96/CE, the matalajännittdirektiivistä 2006/95/CE, SFS-EN ISO 12100-1:2003 Koneurvaluisuus ja niihin liittyvien yhdenmukaistettujen standardien tarvittaessa.  
**Noise Tekniset tiedostot hallussa Ray Neilson at Belle pääkonttori osoite, joka on edellä.**

**(PL)** My, Belle Group Sheen UK, Sheen, Nr. Buxton, Derbyshire, SK17 0EU, Wielka Brytania, niniejszym poświadczamy, iż produkt opisany w tym świadectwie został zakupiony od autoryzowanej Belle Group w UE i jest zgodny z następującymi dyrektywami EU: 2006/42/EY (Niniejsza dyrektywa zastępuje dyrektywę 98/37/EC), Dyrektywą zgodności elektromagnetycznej 2004/108/CE (z poprawkami wniesionymi przez 89/336/EEC, 92/31/EEC & 93/68 EEC), Utylizacją sprzętu elektrycznego i elektronicznego 2002/96/CE, dyrektywą w sprawie niskich napięć 2006/95/CE, BS EN ISO 12100-1:2003 Bezpieczeństwo maszyn i związane normy harmonizacyjne, tam gdzie to ma zastosowanie.  
**Halas techniczne pliki są przechowywane przez Ray Neilsonem na grupy głowy Belle adres Biura zamieszczonego powyżej.**

PRODUKTYP.....	TIPO PRODOTTO .....	PRODUKTYP.....
MODELL .....	MODELLO .....	MODELL .....
SERIENNR.....	SERIE N°.....	SERIE NR. ....
HERSTELLUNGSDATU .....	DATA DI FABBRICAZIONE.....	TILLVERKNINGSDATUM.....
SCHALLLEISTUNGSPEGEL GEMESSEN / (GARANTIERT) .....	LIVELLO POTENZA SONORA MISURATA / (GARANTITA) .....	LJUDSTYRKA UPPMÄTT / (GARANTERAD) .....
GEWICHT.....	PESO .....	VIKT.....
PRODUKTYP.....	TUOTETYYPPI.....	TYP PRODUKTO.....
MODELL .....	MALLI .....	MODEL .....
SERIE NR. ....	VALMISTUSNRO .....	Nr SERII .....
PRODUKSIJONSDATO .....	VALMISTUSPÄIVÄ .....	DATAPRODUKCI .....
ÄLYDKRAFTIVÄ MÅLT / (GARANTERT) .....	ÄNNOVOIMAKKUUDEN TASO MITATTU / (TAATTU) .....	POZIOM MOCY DŹWIĘKU ZMIERZONY / (GWARANTOWANY) .....
VEKT.....	MASSA .....	WAGA .....



Unterzeichnet von:  
Firmato da:  
Undertecknat:  
Signatur:  
Allekirjoitus:  
Podpisal:  
**Ray Neilson**  
Generalidirektor – Im auftrag von BELLE GROUP (SHEEN) UK.  
Amministratore Delegato – Per conto di BELLE GROUP (SHEEN) UK.  
V.D. – På vägnar av BELLE GROUP (SHEEN) UK.  
Managing Director - På vegne av SOCIETE BELLE GROUP (SHEEN) UK.  
Toimitusjohtaja - BELLE GROUP (SHEEN) UK: n puolesta.  
Dyrektor Zarządzający – w imieniu BELLE GROUP (SHEEN) UK

Erklärungsart - Sheen, Nr. Buxton, Derbyshire, SK17 0EU, UK  
Luogo de dichiarazione - Sheen, Nr. Buxton, Derbyshire, SK17 0EU, UK  
Plats av Förklaring - Sheen, Nr. Buxton, Derbyshire, SK17 0EU, UK  
Sted av Erklæring - Sheen, Nr. Buxton, Derbyshire, SK17 0EU, UK  
Julistuksen paikka - Sheen, Nr. Buxton, Derbyshire, SK17 0EU, UK  
Miejsce deklaracji - Sheen, Nr. Buxton, Derbyshire, SK17 0EU, UK  
Erklärungsdatum - 2015.....  
Data de dichiarazione - 2015.....  
Datum av Förklaring - 2015.....  
Dato av Erklæring - 2015.....  
Julistuksen päivämäärä - 2015.....  
Data deklaracji - 2015.....





## How To Use This Manual

This manual has been written to help you operate and service the 'Duo 350X' Floor Saw safely. This manual is intended for dealers and operators of the 'Duo 350X' Floor Saw.

### Foreword

The '**Machine Description**' section helps you to familiarise yourself with the machine's layout and controls.

The '**Environment**' section gives instructions on how to handle the recycling of discarded apparatus in an environmentally friendly way.

The '**General Safety**' and '**Health and Safety**' sections explain how to use the machine to ensure your safety and the safety of the general public.

The '**Operating Instructions**' section helps you with the setting up and use of the machine.

The '**Trouble Shooting Guide**' helps you if you have a problem with your machine.

The '**Service & Maintenance**' section is to help you with the general maintenance and servicing of your machine.

The '**Warranty**' Section details the nature of the warranty cover and the claims procedure.

### Directives with regard to the notations.

Text in this manual to which special attention must be paid are shown in the following way:



#### CAUTION

*The product can be at risk. The machine or yourself can be damaged or injured if procedures are not carried out in the correct way.*



#### WARNING

*The life of the operator can be at risk.*



## WARNING



#### WARNING

*Before you operate or carry out any maintenance on this machine **YOU MUST READ and STUDY** this manual.*

**KNOW** how to safely use the unit's controls and what you must do for safe maintenance. (NB Be sure that you know how to switch the machine off before you switch on, in case you get into difficulty.)

**ALWAYS** wear or use the proper safety items required for your personal protection. If you have **ANY QUESTIONS** about the safe use or maintenance of this unit, ASK YOUR SUPERVISOR OR CONTACT: **ALTRAD BELLE (UK): +44 (0) 1298 84606**



## Contents

How to use this manual.....	4
Warning.....	4
Machine Description.....	5
Technical Data.....	5
Decals.....	6
General Safety.....	7
Health and Safety.....	7
Environment.....	8
Pre-Start Checks.....	8
Start & Stop Procedure.....	8
Operating Instructions.....	8 - 9
Trouble Shooting Guide.....	9
Service and Maintenance.....	10
Blade Fitment.....	11
Warranty.....	12
Declaration Of Conformity.....	2

*Altrad Belle reserves the right to change machine specification without prior notice or obligation.*

## Machine Description

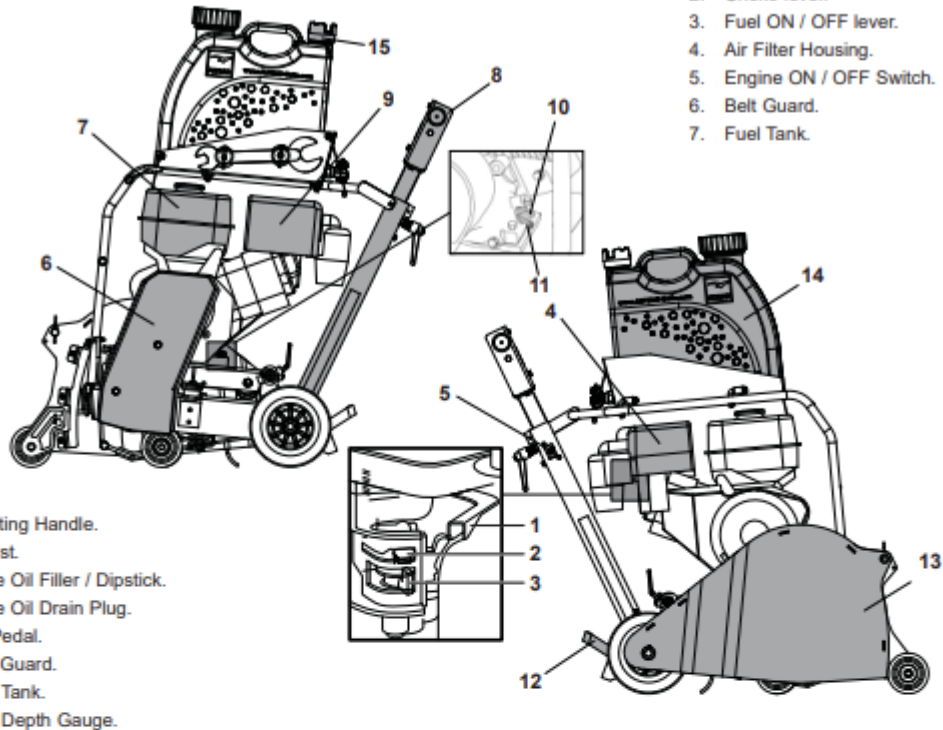

1. Throttle lever.
2. Choke lever.
3. Fuel ON / OFF lever.
4. Air Filter Housing.
5. Engine ON / OFF Switch.
6. Belt Guard.
7. Fuel Tank.

8. Operating Handle.
9. Exhaust.
10. Engine Oil Filler / Dipstick.
11. Engine Oil Drain Plug.
12. Foot Pedal.
13. Blade Guard.
14. Water Tank.
15. Water Depth Gauge.

## Technical Data



Model	Duo 350X
Machine Width (mm)	618
Machine Height (mm)	1019
Machine Length (mm)	870
Engine Model	Honda GX390
Engine Type	Petrol
Motor Power (hp)	13
Machine Weight (Kg)	120
Blade Speed (rpm)	3600
Cutting Width (mm)	100
Maximum Cutting Depth (mm)	120
Blade Diameter (mm)	350
Water Tank Capacity (Ltrs)	25
3 Axis Vibration (m/sec <sup>2</sup> )	3.67
Usage Time (mins)	223
Noise Level (dB(A))	114
Suitable Materials for Cutting:-	Concrete, Asphalt

GB

## Decals

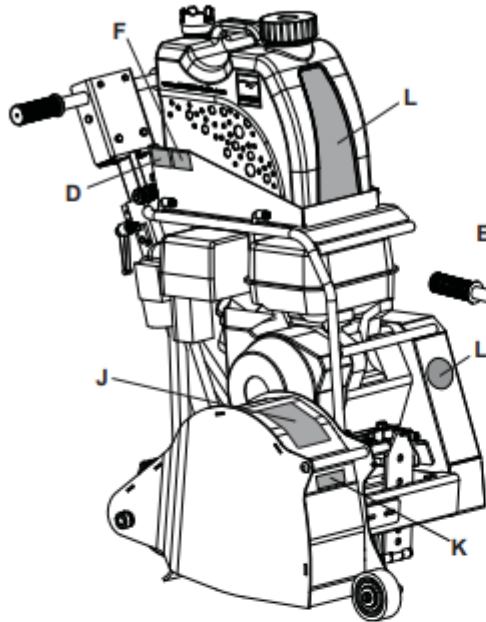

- F. Safety Decal
- G. Risk of Cutting Decal
- H. Displacement Warning Decal
- J. Blade Fitment Decal
- K. Blade Safety Decal
- L. Branding Decals

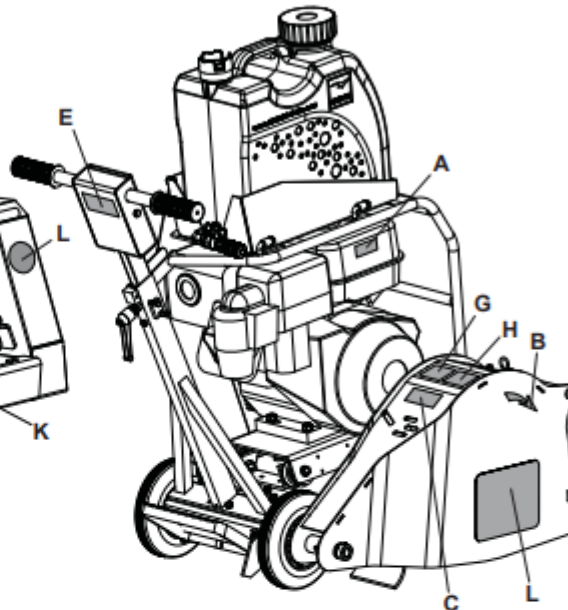

- A. Blade RPM Decal
- B. Blade Pointer Decal
- C. Dust Suppression Decal
- D. Noise Decal
- E. Low HAV Decal

### **A - Blade RPM Decal (800/99576)**

The Maximum Blade RPM is 3800.

### **B - Blade Pointer Decal (154.0.047)**

The Blade rotates clockwise.

### **C - Dust Suppression Decal (800/99573)**

WHEN DRY CUTTING, DUST WILL:-

1. Block Filters and cause premature Engine failure.
2. Pollute the atmosphere.

TO PREVENT THIS:-

1. Use water to dampen the dust down.
2. Ensure that the Water Bottle is full and the Spray System is operational.

### **D - Noise Decal (800/99972)**

The Noise Level of the machine during operation is 114 dB(A)

### **E - Low HAV Decal (800/99874)**

The machine has a UK Patented Design which reduces HAV levels allowing a greater Usage Time.

**Decals**



**F - Safety Decal (Part No. 19.0.373)**



Please Read  
Operators Manual



Wear Protective  
Footwear



Wear Ear  
Protection



Wear Eye  
Protection

**G - Risk of Cutting Decal (800/99575)**

Caution, there is a risk of cutting whilst using this machine.

**H - Displacement Decal (800/99574)**

All displacement of the machine outside the cutting area shall be carried out with the blade not in rotation.

**J - Blade Fitment Decal (800/99303)**

Instructions on how to change a Blade safely. More instructions can be found in the 'Blade Fitment' section.

**K - Blade Safety Decal (800/99395)**

Instructions on how to use the Blade(s) safely.

**GB**

## General Safety

For your own personal protection and for the safety of those around you, please read and ensure you fully understand the following safety information. It is the responsibility of the operator to ensure that he/she fully understands how to operate this equipment safely. If you are unsure about the safe and correct use of the Duo 350X Floor Saw, consult your supervisor or Altrad Belle.



**WARNING**

*Improper maintenance can be hazardous. Read and understand this section before you perform any maintenance, service or repairs.*

- **DO NOT** lift this machine single-handedly, either **GET HELP** or use suitable lifting equipment.
- **DO NOT** leave the engine running and unattended.
- **DO NOT** remove or tamper with any guards fitted, they are there for your protection. Always check guards for condition and security, if any are damaged or missing, **DO NOT USE THE FLOOR SAW** until the guard has been replaced or repaired.
- **DO NOT** operate the machine with the blade guard in the raised position.
- Running the blades whilst loose may result in permanently damaging the machine. Ensure the blades are adequately tightened before operating the machine. Refer to the Blade Fitment section of the manual for more details.
- **DO NOT** operate the Duo 350X Floor Saw when you are ill, feeling tired, or when under the influence of alcohol or drugs.
- **DO NOT** leave the saw unattended with the motor running.
- **DO** cordon off the work area and keep members of the public and unauthorised personnel at a safe distance.
- **DO** all parts of your body away from the cutting blade and any other moving parts.
- **DO** wear Personal Protective Equipment (PPE) whenever operating this equipment. (See Health & Safety).
- **DO** make sure you know how to safely switch this machine **OFF** before you switch it **ON** in case you get into difficulty.
- **DO** switch **OFF** the engine before transporting, moving it around the site or servicing it.
- **DO** allow the engine to cool before touching it because during use it becomes very hot.
- **DO** inspect the blade, flanges and shafts for signs of damage before fitting the new blade.
- **DO** only use blades that are marked with a higher operating speed than the blade shaft speed.
- **DO BEWARE** of Potential Hazards during operation. E.g. Underground Cables & Gas Pipes.
- If using the Duo 350X Floor Saw as a Single Blade Saw, be sure to use the Inner Blade only.

**Fuel Safety.**

- **DO NOT** smoke or allow naked flames in the area when refuelling.
- **DO NOT** operate petrol engines in an enclosed area unless it is sufficiently ventilated.
- **DO NOT** operate the saw in areas which may contain combustible material. Sparks from the cutting process may cause a fire or explosion.
- **DO** switch off the engine and allow it to cool before refuelling.
- Spilt fuel must be made safe immediately, using sand. If fuel is spilt on your clothes, change them.
- Store fuel in an approved, purpose made container away from heat and ignition sources.



**WARNING**

*Fuel is flammable. It may cause injury and property damage. Shut down the engine, extinguish all open flames and do not smoke while filling the fuel tank. Always wipe up any spilled fuel.*

**GB**

## Health And Safety

**Vibration.**

Some vibration from the floor saw operation is transmitted through the handle to the operator's hands. The Altrad Belle floor saw has been specifically designed to reduce hand/arm vibration levels. Refer to specifications & technical data for vibration levels and usage times (recommended maximum daily exposure time). **DO NOT** exceed the maximum usage times.

**PPE (Personal Protective Equipment).**

Suitable PPE must be worn when using this equipment i.e. Safety Goggles, Gloves, Ear Defenders, Dust Mask and Steel Toe capped footwear. Wear clothing suitable for the work you are doing. Tie back long hair and remove any jewellery which may catch in the equipment's moving parts.

**Dust.**

The sawing process will occasionally produce dust, which may be hazardous to your health. Always wear a mask that is suited to the type of dust being produced.

**Fuel.**

Do not ingest fuel or inhale fuel vapours and avoid contact with your skin. Wash fuel splashes immediately. If you get fuel in your eyes, irrigate with copious amounts of water and seek medical attention as soon as possible.

**Exhaust Fumes.**

Do not operate the Duo 350X Floor Saw indoors or in a confined space, make sure the work area is adequately ventilated.



**WARNING**

*The exhaust fumes produced by this equipment are highly toxic and can kill!*



## Environment



### Safe Disposal.



Instructions for the protection of the environment. The machine contains valuable materials. Take the discarded apparatus and accessories to the relevant recycling facilities.

Component	Material
Handle	Steel
Hand Grips	Rubber
Main Frame	Steel
Petrol Engine	Aluminium
Various Parts	Steel and Aluminium

## Pre-Start Checks



### Pre start-up inspection.

The following Pre-start-up inspection must be performed before the start of each work session or after every four hours of use, whichever is first. Please refer to the service section for detailed guidance. If any fault is discovered, the floor saw must not be used until the fault is rectified.

1. Thoroughly inspect the floor saw for signs of damage. Check components are present and secure. Pay special attention to the blade safety guard.
2. Check fluid lines, hoses filler openings, drain plugs and any other areas for signs of leakage. Fix any leaks before operating.
3. Check the engine oil level and top up as necessary.
4. Check the engine fuel level and top up as necessary.
5. Check for fuel and oil leaks.

## Start & Stop Procedure



**WARNING** Before you operate or carry out any maintenance on this machine **YOU MUST READ and STUDY** this manual.

### Honda GX390 Petrol Engine

1. Ensure that the blade is fully raised in the guard by means of the foot pedal.
2. Open the fuel tap by moving the fuel ON / OFF lever fully to the right.
3. If starting the engine from cold, set the choke ON by moving the choke lever fully to the left. If restarting a warm engine, the choke is usually not required, However, if the engine has cooled to a degree, partial choke may be required.
4. Turn the engine ON / OFF switch clockwise to the 'I' position.
5. Set the throttle to the idle position by moving the throttle lever fully to the right.
6. Taking a firm hold of the control handle with one hand, grasp the recoil starter handle with the other. Pull the recoil starter until engine resistance is felt, then let starter return.
7. Taking care not to pull the starter's rope fully out and pull the starter handle briskly.
8. Repeat until the engine fires.
9. Once the engine fires gradually set the choke lever to the OFF Position by moving it to the right.
10. If the engine fails to fire after several attempts, follow the trouble-shooting guide.
11. To stop the engine, fully raise the blade into the guard and set the throttle to idle. Allow the engine to idle for at least 2 minutes
12. Turn the engine ON / OFF switch anti-clockwise to the '0' position.
13. Turn the fuel off.

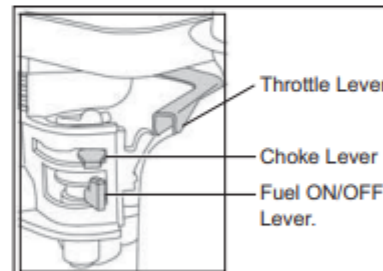

**GB** **Operating Instructions**

- **Take the Floor Saw to where it is required.**  
If the Floor Saw is to be transported to another location, ensure that the Blade is fully raised in the Guard and that the Engine has been switched OFF. **NEVER** transport the Floor Saw with the Blade lowered or with the Engine still running, even if it is only being moved a short distance.

Check that the Water Outlet Valve is closed, then fill the Water Bottle with clean water. To ensure a steady stream of water, always make sure that the Water Bottle water level is kept constant.

If a Bowser is used, ensure that the Water Outlet Valve is closed before connecting the supply to the saw. Once connected, use the Valve to control the flow of water and to ensure a steady stream of water to the Blade.

 **CAUTION** *The Duo 350X can also be used as a Single Blade Floor Saw. Please ensure that the **Inner Blade** is always used in these instances.*

- **Having carried out the checks listed in the 'pre start' section, you may start the engine.**  
The Blade should now be spinning at idle speed. **ALWAYS** check the blade for any signs of wobble, vibration or unusual noise. If any of these occur, stop the machine immediately and refer to the Troubleshooting Guide.

- **Set the throttle to maximum, use the control lever to gently lower the Blade into the cut and use the depth marker to achieve the required depth of cut.**

The Floor Saw will then require gentle forward movement to achieve the cut.

The speed of travel will be determined by the condition of the surface being cut.

**DO NOT** stand in line with the Blade and the stream of hot particles whilst sawing.

**NEVER** plunge the Blade harshly into the cut.

If the surface to be cut is very hard, the saw will take longer to cut. Try to make more than one pass as this will reduce otherwise excessive wear of the Blade.

**DO NOT** try to force the Floor Saw forwards as this will cause damage to the Blade.

**DO NOT** try to cut curves as this will cause stress cracks or fragmentation of the Blade.

- To stop the Floor Saw, follow the Start / Stop Procedure.

**GB** **Troubleshooting Guide**

Problem	Cause	Remedy
Engine will not start.	No fuel.	Open fuel tap. Fill fuel tank.
	Engine switched off.	Switch engine on.
	Spark plug fouled.	Clean and reset plug gap.
	Engine cold.	Close choke.
	Engine flooded.	Honda, open choke, fully open throttle, pull recoil starter until engine fires.
Blade not turning	Belts incorrectly tensioned.	Re-tension belts.
	Belts broken.	Replace belts.
Excessive Noise, Vibration or wobble from blade.	Check condition of arbor shaft bearings.	Replace as necessary.
	Check dowel pin for damage.	Replace dowel pin.
	Check tightness of arbor shaft nut.	Tighten as necessary.
	Check condition of Blade flange.	Replace as necessary.
	Check Blade for signs of damage.	Replace blade.

## Service and Maintenance



### CAUTION

*Improper maintenance can be hazardous. Read and Understand this section before you perform any maintenance, service or repairs.*

#### Maintenance

The Altrad Belle 'Duo 350X' Floor Saw is designed to give many years of trouble free operation. It is, however, important that the simple regular maintenance listed in this section is carried out. It is recommended that an approved Altrad Belle dealer carries out all major maintenance and repairs.

Always use genuine Altrad Belle replacement parts, the use of spurious parts may void your warranty. Before any maintenance is carried out on the machine, switch off the engine. *Petrol engine* - disconnect the HT lead from the sparkplug. Always set the Floor Saw on level ground to ensure any fluid levels will be correctly read.

Only use recommended oils (see chart below).

#### Running In Period

When the Floor Saw is first used from new, the engine oil must be changed after the initial running in period (see engine manual for full detail). The belt tension should be checked after 4 hours use. If new Belts have been fitted, check Belt tension after the first 30 minutes of use.

#### Drive Belt

Remove the Belt Guard then check the Belt tension by placing light finger pressure on the top of the Belt, as near central between the engine drive and arbor pulley. The Belt should deflect by 4mm. If the Belt tension requires adjustment, loosen the Engine Mounting Bolts enough to allow the Engine to be moved. Adjust the Engine's position by adjusting the tensioning Bolt at the front of the machine. Once set, re-tighten the Engine Mounting Bolts and check the Belt tension a second time. Once the Belt tension is correct, check the Pulley alignment. If the alignment is incorrect, loosen the Taperlock Bushes and move the Pulley to suit. Once the alignment is correct, re-tighten the Taperlock Bushes. Finally, replace the Belt Guard ensuring it is correctly and securely fitted.

Routine Maintenance		Daily	After First 4 Hours	First Month / 20 Hours	3 Months / 50 Hours	6 Months / 100 Hours
Engine Oil	Check Level		✓			
	Change			✓		✓
Air Filter	Check Condition			✓		✓
	Clean / Replace				✓	
Spark Plug	Check / Clean					✓
Drive Belt	Tension		✓	✓	✓	
Blades	Check Tightness	✓				

#### Oil / Fuel Type & Quantity - Spark Plug Type

	Oil Type	Quantity (Litre)	Fuel Type	Capacity (Litre)	Spark Plug Type	Electrode Gap (mm)
Petrol Honda GX390	S.A.E. 10W 30	1.1	Unleaded	6.4	BM6ES or BPR6ES	0.6 - 0.7

#### Removal of Arbor Shaft

1. Remove Belt Guard, Belts, lower Taperlock Bush and Drive key.
2. Tilt the machine backwards to allow access to Arbor Shaft Bearings.
3. Heat Grubscrews on Bearings .
4. Remove the 2 x Grubscrews on the Blade side and the 2 x Grubscrews on the Drive Bearing and remove the Shaft.
5. Clean and replace Arbor Shaft and line the groove up on the Blade end with the Grubscrews.
6. Re-insert Grubscrews at both ends and secure using Loctite 638.



## Blade Fitment



### CAUTION

*Incorrect fitting of a Blade can cause serious injury. Ensure that the fitting instructions are followed. If in any doubt, Contact your supervisor or Altrad Belle.*



### WARNING

*DO NOT operate the Floor Saw with the Blade Guard in the raised position. This may caused serious injury.*

1. Remove the HT lead from the Spark Plug.
2. Raise the front of the Floor Saw to its maximum height using the foot pedal.
3. Remove the R-Clip (1) and Pin (2) from the Blade Guard and raise the Guard. Lock in place with the same R-Clip and Pin. Ensure the Guard is locked into place.
4. Remove the Arbor Shaft Nut (5) Blade Clamping Plate (4) the Blade Spacer (6) and the two Blades using the Spanners provided.
5. Check the clamping plate and backing plates for damage or wear. Replace if necessary, and fit the blade as laid down in the **safety codes USA ANSI B7.1, Canada SCA and Great Britain HMSO No. 4.**
6. Clean the Flange before mounting the Blade.
7. Be sure that the arrow on the blade points in the same direction as the rotation of the tool.
8. Fit genuine Altrad Belle Blades on to the Arbor Shaft making certain that the Blades locate on to the Arbor Shaft boss and is flush with the Flange Plate.
9. Replace the Clamping Plate (4) with the Dowel Pin (3) passing through the Blade into the rear flange plate.
10. Replace the Arbor Shaft Nut (5) and secure firmly using Spanners provided with the saw (Image 3)
11. Remove the R-Clip (1) and Pin (2) from the Blade Guard and lower the Guard. Lock in place with the same R-Clip and Pin. Ensure the Guard is locked into place.
12. Reconnect the HT lead to the Spark Plug.
13. The machine is now ready to be used.

**NOTE:-** When a Blade is changed, ensure the Guard Pivot Point is sufficiently lubricated.

**NOTE:-** If using the Duo 350X Floor Saw as a Single Blade Saw, be sure to use the Inner Blade only.

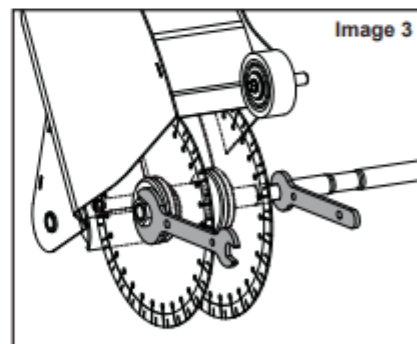
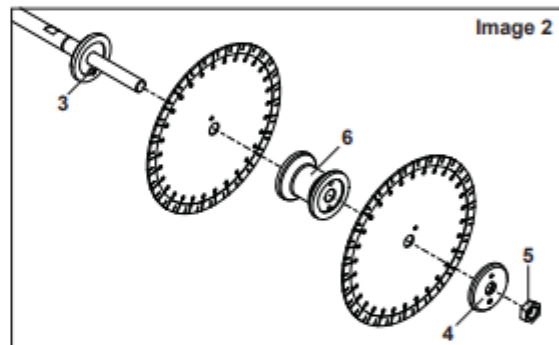
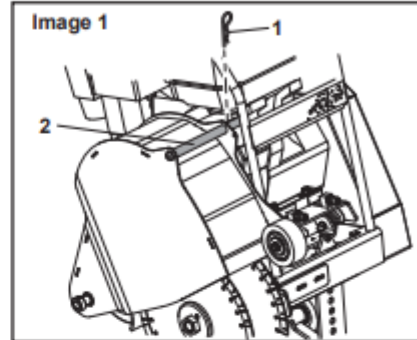



## Warranty



Your new Altrad Belle Duo 350X Floor Saw is warranted to the original purchaser for a period of one-year (12 months) from the original date of purchase. The Altrad Belle warranty is against defects in design, materials and workmanship.

The following are not covered under the Altrad Belle warranty:

1. Damage caused by abuse, misuse, dropping or other similar damage caused by or as a result of failure to follow assembly, operation or user maintenance instructions.
2. Alterations, additions or repairs carried out by persons other than Altrad Belle or their recognised agents.
3. Transportation or shipment costs to and from Altrad Belle or their recognised agents, for repair or assessment against a warranty claim, on any machine.
4. Materials and/or labour costs to renew, repair or replace components due to fair wear and tear.

The following components are not covered by warranty:

- Drivebelt/s
- Engine air filter
- Engine spark plug

Altrad Belle and/or their recognised agents, directors, employees or insurers will not be held liable for consequential or other damages, losses or expenses in connection with or by reason of or the inability to use the machine for any purpose.

### Warranty Claims

All warranty claims should firstly be directed to Altrad Belle, either by telephone, by Fax, by Email, or in writing.

### For warranty claims:

Tel: +44 (0)1298 84606

Fax: +44 (0)1298 84073

Email : [Warranty@belle-group.co.uk](mailto:Warranty@belle-group.co.uk)

### Write to:

Altrad Belle Warranty Department,  
Sheen, Nr. Buxton,  
Derbyshire,  
SK17 0EU  
England.

### Warranty Registration:

In the bid for ALTRAD Belle to become greener and more eco friendly, we have now introduced online Warranty registration. To access the registration page of our website, please use the following address:-

[http://www.bellegroup.com/index.php?p=warranty\\_registration](http://www.bellegroup.com/index.php?p=warranty_registration)

Alternatively, please scan the adjacent QR Code (Quick Response Code) using your smartphone to access the registration page.

















