

NEW



## TOOL CARRIER | 3CX COMPACT

Gross power: 55kW (74hp) Maximum dig depth: 4.33m Weight: 6070kg





# Introducing the **3CX Compact** the ultimate tool carrier..

JCB pioneered the backhoe loader in 1953 introducing many innovative features to the market. And in a rapidly changing world, JCB continues to evolve to meet customer demands. Our latest innovation, the 3CX compact is the answer to those changing needs. Find out why it is the ultimate tool carrier.









## MORE COMPACT.

SPACE IS BECOMING A PREMIUM. THAT'S WHY THE NEW 3CX COMPACT HAS BEEN DESIGNED TO GIVE YOU BIG PERFORMANCE IN A SMALL AREA. THIS MAKES IT PERFECT FOR URBAN WORKING AND RESTRICTED CONSTRUCTION SITES.

**1** Ideal for the tightest urban applications with minimal disruption, due to the ability to road to site. These jobs are often completed by hand.

**2** At only 1.95m wide the 3CX Compact is almost half a meter narrower than a standard backhoe (attachment dependant). And a 2.74m travel height allows the 3CX Compact to access much tighter spaces.

**3** The low height unlocks a whole new range of previously inaccessible work sites, such as low level buildings and basements.

**4** Its narrow width makes the 3CX Compact ideal for entering gardens, parks and small construction sites with restricted access.





**35%** smaller than  
a standard backhoe.





## MORE MANOEVRABLE.

THE NEW 3CX COMPACT IS THE ULTIMATE IN MANOEVRABILITY. ITS TIGHT TURNING CIRCLE AND SWITCHABLE STEERING MODES ALLOW IT TO WORK IN A SINGLE CARRIAGEWAY WITH MINIMUM DISRUPTION AND MAXIMUM PRODUCTIVITY.

**1** Switchable 2WS/4WS allows the operator to change between roading mode to site with ease.

**2** An impressive 5.8 metre turning circle (with applied brakes) allows the machine to turn a full 180 degrees in a single carriageway.

**3** A three speed 40kph hydrostatic transmission makes the 3CX Compact an incredibly independent machine with a large working radius for optimum productivity without the reliance on other equipment to transport.

**4** The 3CX Compact is powered by a high torque 55kW (74hp) JCB by Kohler engine that requires no after treatment keeping servicing costs and downtime to a minimum.



**1** Four-wheel steer Two-wheel steer



**3**



**2**

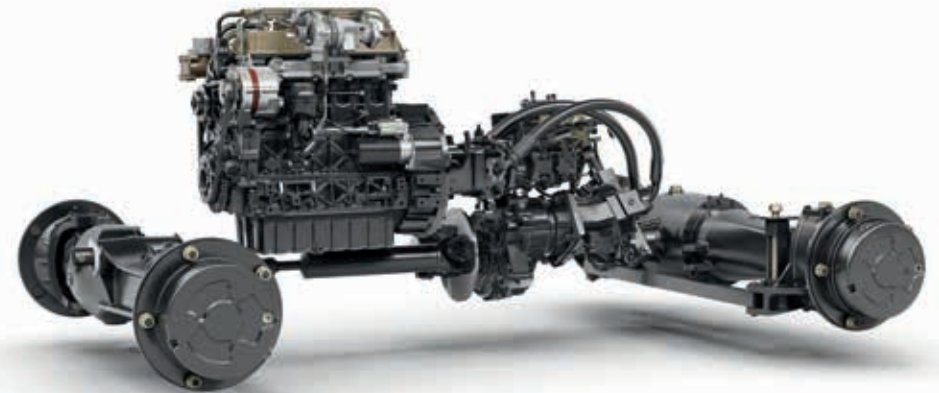

**4**



**16%** tighter turning circle  
than a standard backhoe.

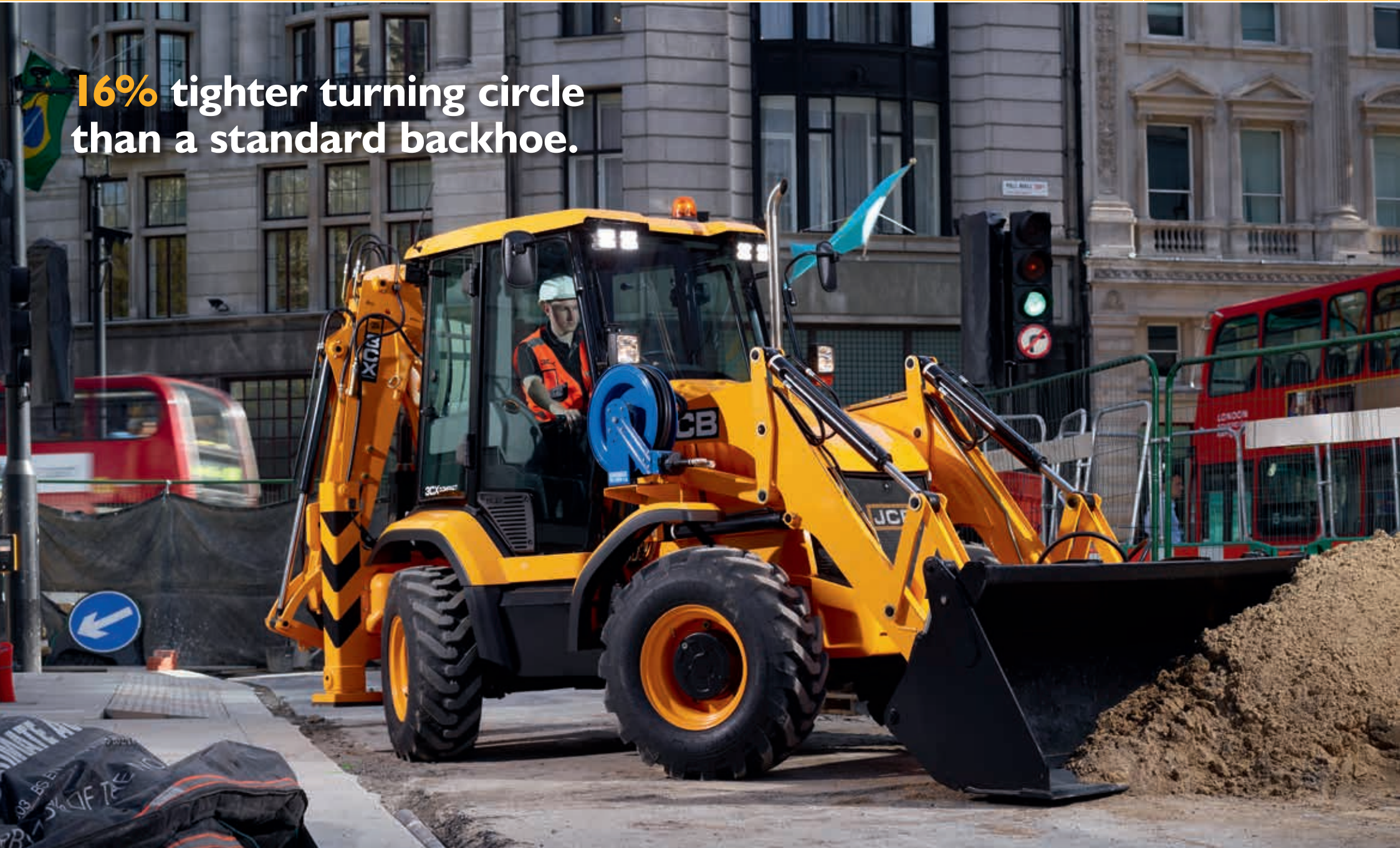



## MORE VERSATILE.

THE 3CX COMPACT IS NOT ONLY DESIGNED FOR THE VAST RANGE OF TOOL CARRIER ATTACHMENTS. IT ALSO HAS THE ABILITY TO PICK UP A WIDE RANGE OF SKID STEER LOADER ATTACHMENTS. BI-DIRECTIONAL PIPEWORK AND A HANDHELD TOOL CIRCUIT PROVIDE EVEN GREATER VERSATILITY.

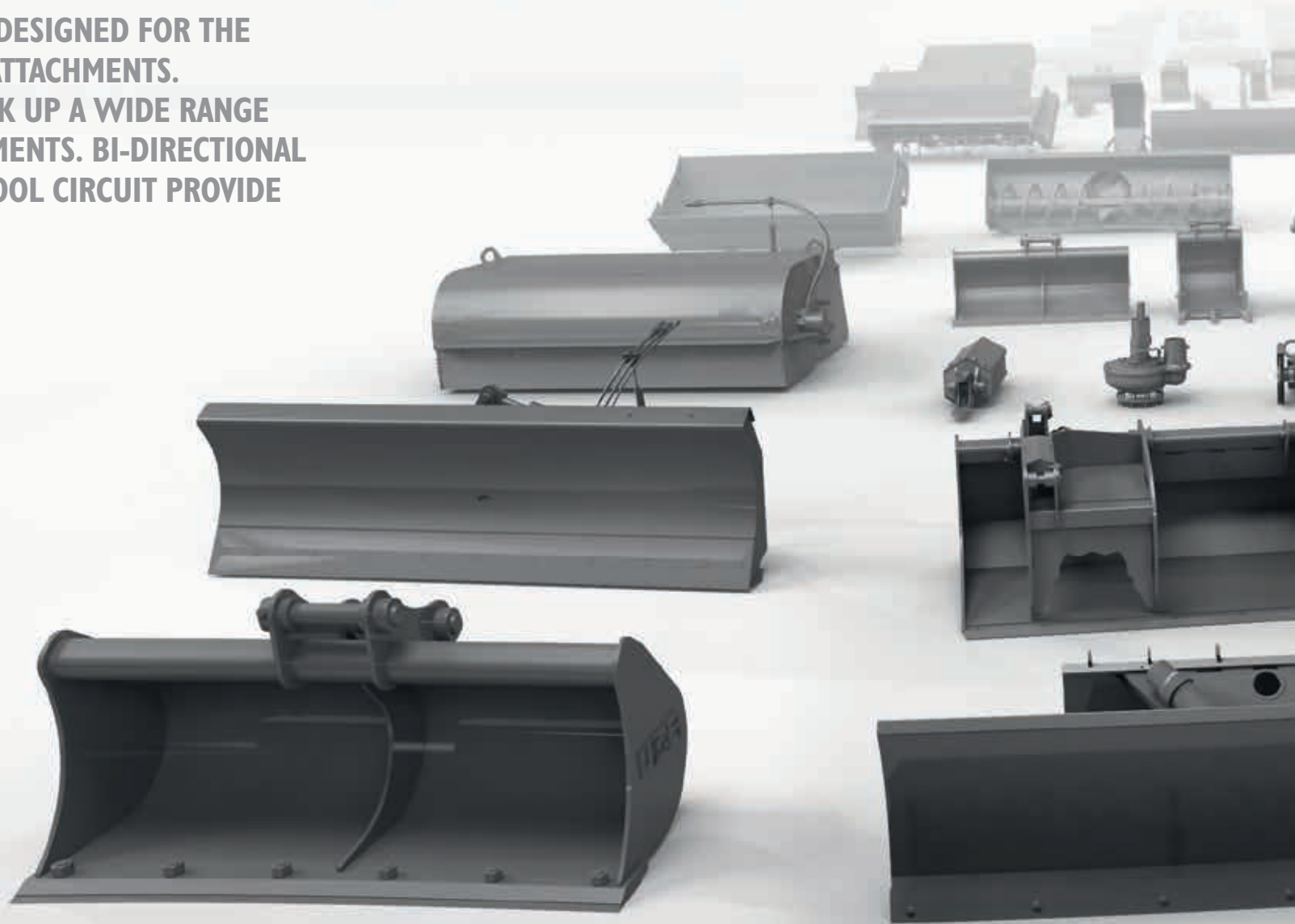



The **versatile** one machine solution.





## EASIER TO OPERATE.

A SPACIOUS CAB WITH EXCAVATOR CONTROLS PROVIDES OPTIMUM EASE OF USE AND CONTROLLABILITY. THIS ALSO HELPS TO IMPROVE THE OPERATOR'S SEATING POSITION, WHICH IN TURN MAKES IT A LOT MORE COMFORTABLE.

**1** Three speed controls allow the correct speed to be selected simply at the touch of a button

**2** Excavator style controls are fitted as standard providing ease of use and controllability.

**3** A fully adjustable suspension seat provides fatigue free all-day operation.

**4** A front dash mounted display provides all the information when roading and loading.

**5** A 12V auxiliary circuit for powering of useful accessories, such as mobile phones.

**6** For ultimate customisation choose our optional SAE+ /ISO+ control pattern switch.





Excavator style **servo controls**  
come as standard.





## GREAT RETURN ON INVESTMENT.

JCB'S LEGENDARY BUILD QUALITY AND GLOBAL BRAND HELP KEEP CUSTOMER DEMAND AND MACHINE RESIDUALS HIGH. AND THE BENEFITS OF OWNING A NEW 3CX COMPACT DON'T STOP THERE.

**1** We've used only proven reliable components on the 3CX Compact to maximise uptime and ensure that your machine spends as much time as possible earning you money.

A 40kph road speed eliminates the need to hire or purchase a lorry for transport .



**2** A high specification at a competitive price gives you maximum value for money. A full range of attachments increase versatility and allow for greater rental return.



**3** LiveLink is standard enabling you to monitor utilisation of your investment, fuel consumption and machine location.



**4** JCB backhoe loaders have become a global currency, due to their enviable reputation for both quality and high residual values.





Designed for great  
**versatility** and **value.**





# LIVELINK, WORK SMARTER.

JCB LIVELINK USES THE LATEST SATELLITE TECHNOLOGY TO HELP YOU MONITOR AND MANAGE YOUR MACHINE REMOTELY ANYWHERE IN THE WORLD VIA WEB, EMAIL OR MOBILE. SO WHETHER YOU'RE AN OWNER OPERATOR OR RUN A FLEET, LIVELINK CAN RADICALLY IMPROVE THE EFFICIENCY AND SECURITY OF YOUR MACHINES.

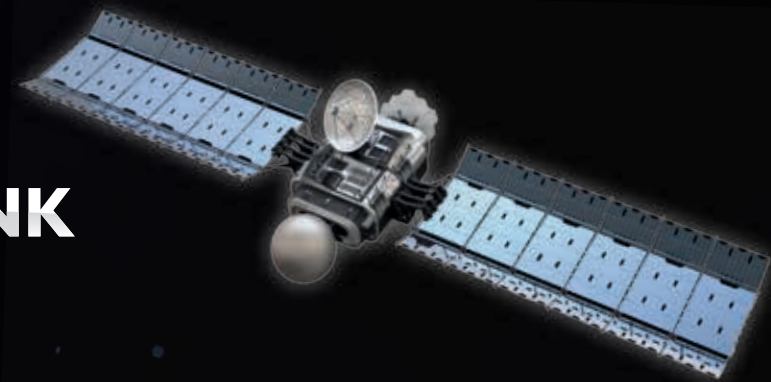

## Machine efficiency

1 By providing information like idle time monitoring and fuel consumption, JCB LiveLink saves you money and improves productivity.

## Machine reliability

2 Accurate hours monitoring and service alerts improve maintenance planning and help rental companies with accurate charging. Technical alerts and maintenance history records help you manage your machines.

## Machine monitoring

3 Keep track of what your machine's been doing throughout the day with regular performance reports accessed via the LiveLink website.

## Machine Security

4 LiveLink's real time geo-fencing alerts tell you when machines move out of predetermined zones. Curfew alerts inform you of unauthorised usage. JCB have a history of working with the police to recover stolen machines and tackle fuel theft.





## VALUE ADDED.

JCB'S WORLDWIDE CUSTOMER SUPPORT IS FIRST CLASS. WHATEVER YOU NEED AND WHEREVER YOU ARE, WE'LL BE AVAILABLE QUICKLY AND EFFICIENTLY TO HELP MAKE SURE YOUR MACHINERY IS PERFORMING TO ITS FULL POTENTIAL.



1

1 Our Technical Support Service provides instant access to factory expertise, day or night, while our Finance and Insurance teams are always on hand to provide fast, flexible, competitive quotes.

2 The global network of JCB Parts Centres is another model of efficiency; with 16 regional bases, we can deliver around 95% of all parts anywhere in the world within 24 hours. Our genuine JCB parts are designed to work in perfect harmony with your machine for optimum performance and productivity.



2

3 JCB Assetcare offers comprehensive extended warranties and service agreements, as well as service-only or repair and maintenance contracts. Irrespective of what you opt for, our maintenance teams around the world charge competitive labour rates, and offer non-obligation quotations as well as fast, efficient insurance repair work.



3

Note: JCB LIVELINK and JCB ASSETCARE may not be available in your region, so please check with your local dealer.

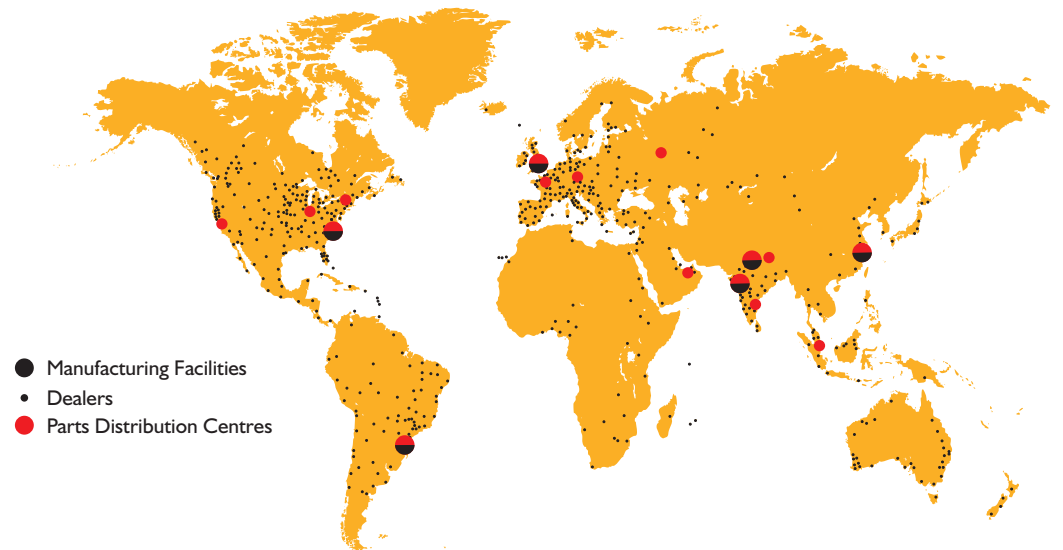

## PERFECT FOR ROAD RESURFACING.

WHEN IT COMES TO ROAD RESURFACING, VERSATILITY AND SPEED WITH MINIMAL DISRUPTION ARE PARAMOUNT. THE NEW 3CX COMPACT CAN TRAVEL QUICKLY AROUND SITE. IT CAN TURN AND WORK IN A SINGLE CARRIAGEWAY AND EVEN DRIVE OVER FRESH ASPHALT IT IS THE PERFECT MACHINE FOR ROAD RESURFACING.

**1** The 3CX Compact can drive over fresh asphalt unlike skid steer loaders and excavators, due to its 6 tonne weight, 4-wheel-steer and rubber tyres.

40kph travel speed and a 5.8m turning circle make the machine quick and nimble around busy job sites.

**2** At only 6 tonnes and 2.74m tall this machine can be easily transported along with all equipment needed to complete the job.

**3** Excellent visibility due to a commanding driving position and large glass window area.

**4** Designed for the job. The tool carrier has been the product of choice for this application for the last 20 years. Street pads is just one example of a customer specified feature.







### 6 in 1 shovel

Six applications with one attachment (dig, doze, grab, grade, load and backfill). Bolt on hardened toe plate fitted for increased attachment life.

### Breaker

Fitted with a dipper mounted HM166Q breaker, ideal for breaking the top layer of asphalt, prior to planing when road resurfacing.

### Handheld tool circuit

The 9m hose reel provides power to a wide variety of hydraulic tools in a large working radius, and its auto retract system makes it easy to put away after use.

### LED Work Lights

2 front and 4 rear high powered LED lights as standard give you daylight working conditions at night. Optional 10 LED pack also available.

### Street pads

Stabiliser street pads reduce damage to road surfaces. Shovel street pads are also available for increased protection.

### Additional features and attachments

Switchable ISO/SAE controls; Handheld HM25LV breaker with external holster; Lifting kit.



## IDEAL FOR ROAD REPAIRS.

THE 3CX COMPACT IS AVAILABLE WITH THE PERFECT SPECIFICATION TO BE A SINGLE-MACHINE SOLUTION FOR PERMANENT POTHOLE REPAIR PREPARATION, COLLAPSED DRAINS, KERBS AND MORE. WITH A POWERFUL PATCH PLANNER, SWEEPER COLLECTOR AND TOW HOOK TO BRING TO SITE USEFUL HANDHELD TOOLS, IT REALLY IS THE ULTIMATE IN ROAD REPAIRS.

**1** A handheld tool circuit allows use of power tools such as disc cutters or breakers. The tools can even be used at the same time as the attachments on the machine.



**2** The ability to do perfect preparation for a permanent pothole repair by planing, cutting and sweeping up.



**3** A compact size allows it to work in confined areas that are inaccessible for standard size backhoes.



**4** Under 6m turning circle means it can work in a single carriageway allowing a road to be kept open.



**5** The versatility to do the work of multiple machines like drainage, forkwork, moving kerbstones and carrying material such as hot tar.







### Sweeper collector

The sweeper collector ensures thorough surface preparation. Its offset design allows work to be carried out in a single carriageway, eliminating disruption to traffic.

### Patch planer

The powerful high speed drum cuts clean vertical sides to any planed area. This allows consistent, clean compaction of new tarmac into the prepared area.

### Handheld tool circuit

The 9m hose reel provides power to a wide variety of hydraulic tools in a large working radius, and its auto retract system makes it easy to put away after use.

### Handheld breaker

A HM25LV breaker is included. This low vibration model provides an excellent power to weight ratio and comes with an external holster.

### Extending dipper

10ft extending dipper reduces the need to reposition the machine, saving valuable time.

### Additional features and attachments

Switchable ISO SAE controls; Stabiliser street pads; LED light kit.



## FITS THE BILL FOR UTILITIES.

THE 3CX COMPACT IS PERFECTLY TAILORED FOR THE UTILITIES SECTOR. IT CAN TRAVEL QUICKLY TO SITE, MANOEUVRE IN TIGHT SPACES AND WORK WITH MULTIPLE ATTACHMENTS FOR TRENCHING WORK AND SITE PREPARATION. ALL THIS WITH MINIMUM DISRUPTION AND DAMAGE.

**1** 40kph road speed for fast deployment to deal with emergencies such as burst water pipes, gas leaks and telecom repairs. And no need for a low loader.



1

**2** Handheld tool circuit provides additional functionality to use water pumps for flooded trenches, hand breakers and much more.



2

**3** Under 2 metre width means you only have to close off a single carriageway.



3

**4** Under 6 metre turning circle gives it the manoeuvrability to work in confined spaces.



4

**5** The one machine solution for cutting asphalt, digging ground, lifting pipes, carrying and unloading equipment and materials, backfilling, compacting trenches and sweeping up afterwards.



5





**LED kit with dipper mounted work light**

2 front and 4 rear high powered LED lights give you daylight working conditions at night. The dipper mounted work light gives direct light to the working area.

**HM 266Q breaker**

High blow rate breaker with built in sound suppression. A solid body design provides maximum strength and power for excellent breaking performance.

**Handheld tool circuit**

The 9m hose reel provides power to a wide variety of hydraulic tools in a large working radius, and its auto retract system makes it easy to put away after use.

**Extending dipper**

10ft extending dipper increases lifting radius, reducing the need to reposition the machine.

**Street pads**

Street pads on the stabilisers and on the 6 in 1 shovel provide maximum surface protection.

**Additional features and attachments**

ISO/SAE; Lifting kit including HBCV; Handheld breaker; 300 and 600mm buckets with toeplate; Grading bucket; Submersible pump.



## YOUR PAL FOR MUNICIPALITIES.

WITH LOCAL AUTHORITIES AND MUNICIPALITIES HAVING SUCH VARIED RESPONSIBILITIES, ITS VERSATILITY MAKES THE 3CX COMPACT THE PERFECT MACHINE. ITS SIZE LETS IT GET TO JOBS WHERE A BIGGER MACHINE JUST COULDN'T GO. ITS ABILITY TO USE A HUGE RANGE OF ATTACHMENTS INCLUDING HANDHELD TOOLS, MAKES IT A GREAT VALUE, RELIABLE WORK HORSE.

**1** One machine solution that offers great versatility and value for money. It can perform multiple tasks and do the work of both a compact wheeled loader and mini excavator. From park maintenance in the summer to loading gritter lorries and snow clearing in the winter, the 3CX Compact really is a machine for all seasons.



**2** Its ability to quickly travel to and from sites as well as around large areas such as parks means one machine can be very productive.



**3** A handheld tool circuit further increases the ability for one machine to tackle any job, such as pumping water and using augers to plant trees.



**4** The 3CX Compact is lightweight and narrow with excellent manoeuvrability. When combined with turf tyres and the ability to dig to 12 feet, this machine is ideal for grave digging.



**5** Under 2 metre machine width gives it the ability to work in confined areas which are inaccessible to larger machines (attachment dependent).







### 6 in 1 shovel

Six applications with one attachment (dig, doze, grab, grade, load and backfill).

### Front and rear quickhitch

Easily switch between attachments for complete versatility on any job. Both hitches allow for effortless attachment changes.

### 10 foot extending dipper

10ft extending dipper for less repositioning of the machine and in turn higher efficiency. An optional 12ft dipper is also available.

### Handheld tool circuit

The 9m hose reel provides power to a wide variety of hydraulic tools in a large working radius, and its auto retract system makes it easy to put away after use.

### Lifting kit

Tipping link and lifting shackle enable the machine to carry out lifting operations. Hose burst check valves and an audible warning alarm maximise site safety.

### Additional features and attachments

Switchable ISO/SAE; LED light kit; 600mm bucket; Stabiliser street pads.



# THE WORKS FOR **GROUNDWORKS.**

**WHEN IT COMES TO GROUNDWORKS THE 3CX COMPACT WORKS PERFECTLY. DESIGNED TO WORK EFFORTLESSLY AND SAFELY IN TIGHT MODERN HOUSING DEVELOPMENTS WITH THE ABILITY TO UTILISE A WHOLE HOST OF USEFUL ATTACHMENTS, IT REALLY IS PERFECT FROM THE GROUND UP.**

**1** Avoids the need for multiple machines on site such as dumpers, compact wheeled loaders, mini excavators, forklifts and motorised sweepers.

**2** Capable of multiple jobs such as fork work, moving material, digging footings, lifting mortar tubs, site stripping and sweeping to keep the site clean at the end of the day.

**3** Compact size enables the machine to work between houses and access back gardens for landscaping.

Under 6 metre turning circle gives it the manoeuvrability to work in smaller housing developments.

**4** A 40kph road speed allows it to travel to and around site quickly increasing productivity.



**1**



**2**



**3**



**4**





**Dedicated forks**

Industrial forks are perfect for loading, stocking and rehandling. Built-in load guard offers greater operator safety.

**6 in 1 shovel with ram guards**

Six applications with one attachment (dig, doze, grab, grade, load and backfill). Shovel ram guards provide additional protection from debris.

**Handheld tool circuit**

The 9m hose reel provides power to a wide variety of hydraulic tools in a large working radius, and its auto retract system makes it easy to put away after use.

**LSD axles**

The limited slip differential ensures maximum productivity in all ground conditions by providing additional tractive effort.

**Submersible pump**

The self-priming, high powered 700lpm submersible pump that can be used in conjunction with the machine operation.

**Additional features and attachments**

Stabiliser street pads; Lifting kit; 600mm bucket; Switchable ISO/SAE; LED light kit.



**STATIC DIMENSIONS**

Max. Engine power: 55kW (74hp) max. tool carrier dig depth: 4.33m

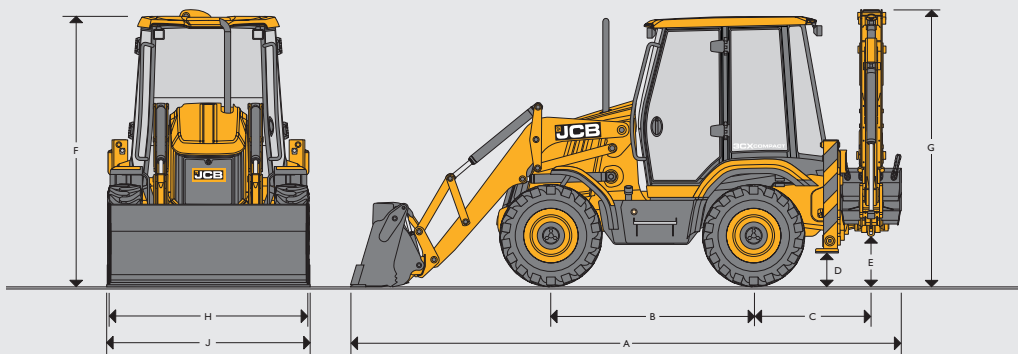

		3CX COMPACT	
A	Total travel length	m	5.54
B	Axle centreline distance	m	1.99
C	Slew centre to rear axle centre distance	m	1.21
D	Stabiliser feet clearance	m	0.24
E	Kingpost clearance	m	0.47
F	Cab roof height	m	2.60
G	Total travel clearance (10ft)	m	2.74
	Total travel clearance (12ft)	m	3.07
H	Rear frame width	m	1.89
J	Shovel width	m	2.00

JCB tool carriers feature heavy-duty one piece mainframe, hydrostatic driveline and fully enclosed engine compartment. All fluid and component compartments are lockable using the ignition key

**GROUND LINE ANGLES**

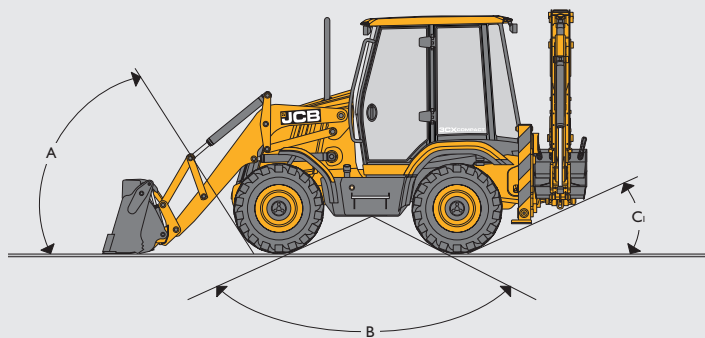

A	Approach angle	degrees	45°
B	Interference angle/ramp to ground plane	degrees	124.5°
C	Departure angle	degrees	19°

**ENGINE**

Common rail diesel. Belt driven water pump. Cold start aid – territory dependent. Single side servicing.

Engine emissions	Stage IIIB/T4	
Manufacturer	JCB Diesel by Kohler Co.	
Gross power	kW (hp)	55 (74) @ 2200rpm
Peak torque	Nm	300
Aspiration	Turbo charged	
Displacement	CC	2482
No. of cylinders	4	
Bore	mm	88
Stroke	mm	102
Rated engine	rpm	2350

**ENGINE SUPPORT SYSTEM**

Engine support system is designed for ease of daily checks, routine maintenance and longer service intervals.

Fuel type	Diesel
Fuel filter	Replaceable spin-on cartridge plus water/sediment separator.
Air cleaner	Dual, dry element type, with self cleaning internal air intake precleaner.
Oil filter and lubrication	Full flow, spin-on filter
Cooling system	Hot climate specification, pressurised 14.5 psi (1.0 bar) suction fan. Pressurised recovery tank.

**ELECTRICAL AND INSTRUMENTATION**

12 volt negative ground, utilising wiring and connectors meeting IP69 water ingress test standard. Central fuse panel supplemented with main circuit breakers at battery positive terminal.

Gauges	Speedometer, engine speed, engine coolant temp, fuel level, hourmeter clock
Warning system	Audible and visual system for engine oil, transmission, park brake, battery, air cleaner, alternator
Battery	900 CCA/110 A/hr.
Pre-wire	Radio speaker (cab), beacon (all)
Horn	Controlled from both front and rear
Alternator	100 amp
Front working lights	2 Halogen adjustable
Rear working lights	4 Halogen adjustable

**TRANSMISSION**

Bosch Rexroth transmission with anti-stall and high speed roading switch.

Type	Hydrostatic	
Model	Rexroth A6VM – 3 speed	
1st (low range)	kph (mph)	6 (3.7)
2nd (high range)	kph (mph)	10 (6.2)
3rd (high speed)	kph (mph)	40 (24.9)



**SERVICE CAPACITIES**

Cooling system	ltr	16
Fuel tank	ltr	80
Engine oil sump	ltr	11.2
Hydraulic system (including transmission)	ltr	104
Rear axle	ltr	9.0
Front drive axle	ltr	9.0

**AXLES**

	Front	Rear
Type	JCB Max-trac steer drive torque proportioning	
Axle ratings	kg	
Static load rating	7484	
Dynamic load rating	3765	
Oscillation angle	9.5°	–
Steering ram	Double acting	Double acting

**STEERING**

Steering axles	Front and rear
Steering turns – lock to lock	4
Turning circle:	m
Inner wheels braked	5.8
Inner wheels not braked	6.7

**OPERATING WEIGHTS**

10ft Extradig	kg	6070
---------------	----	------

Operating weight includes machine with 6-in-1 shovel, 600mm excavator bucket, extended dipper, full fuel tank and operator.

Actual weight will vary depending on machine options.

**BRAKES**

The JCB braking system ensures effective, fade free braking. The self-adjusting, multi-disc arrangement is inboard mounted and is oil immersed for minimum maintenance and a long operating life.

- Split brake pedals provide tighter turning circle and enhanced steering control on slippery ground.
- Automatic compensation ensures 'straight' machine braking.
- Disc diameter: 165mm (6.5in). Friction area: 130502 sq.mm (202 sq.in) per brake.
- The independent parking brake is mounted on the input shaft rear axle.  
High-retraction brakes and transmission disconnect reduce power loss and brake pad wear.

**HYDRAULIC SYSTEM**

Closed centre system (piston pump) offering variable flow hydraulics, providing best in class controllability. ISO control system with a new Eco excavating mode for fuel saving.

Pump flow at 2350rpm	l/min	100*
System relief pressure	bar	230

\*100% efficiency

**TYRES**

340/80 x R18 Michelin XMCL (Radial)

340/80 x R18 Sitemaster Industrial (Cross-ply)

340/80 x R18 Michelin Power CL (Cross-ply)

**NOISE AND VIBRATION LEVELS**

Internal	dB(A)	71
External	dB(A)	101

**CAB**

• Excellent visibility (and safety) is provided by the extra large tinted glass areas. Cab frame is ROPS and FOPS approved for maximum operator protection. ISO standard 3471 and 3449 (SAE J1040 and J231).

- A fully adjustable air suspension seat combines with ergonomically positioned controls to minimise operator fatigue.
- A single DIN radio location is provided as standard plus twin speakers for stereo sound.
- Cab provides easy access through a left hand single door. Standard features include: retractable seat belt, 3 speed fresh air / recycle heater, front and rear screen wash / wipers (cab), front and rear horn, exterior mirrors and flat easy-clean floor.
- Dual instrument panels in the front console for roading and the side console for loading and excavating.
- Fixed steer column.
- Large protected opening rear window (cab).
- 12V power supply.



**LOADER DIMENSIONS**

	G.P. Shovel	6-in-1 shovel	Narrow G.P. shovel
	m	m	m
Overall width with bucket	2.00	2.00	1.37
M Dump height	2.41	2.32	2.35
N Load over height	2.93	2.98	2.96
O Loader hinge pin height	3.18	3.18	3.18
P Pin forward reach	0.4	0.4	0.4
Q Reach at ground (toe plate horizontal)	1.54	1.54	1.58
R Max. reach at full height	1.11	1.11	1.24
S Reach at full height fully dumped	0.64	0.78	0.79
T Dig depth	0.12*	0.12*	0.12*
U Roll back at ground	45°	45°	45°
V Dump angle	45°	45°	45°
Jaw opening width	-	0.7	-

\*With quickhitch.

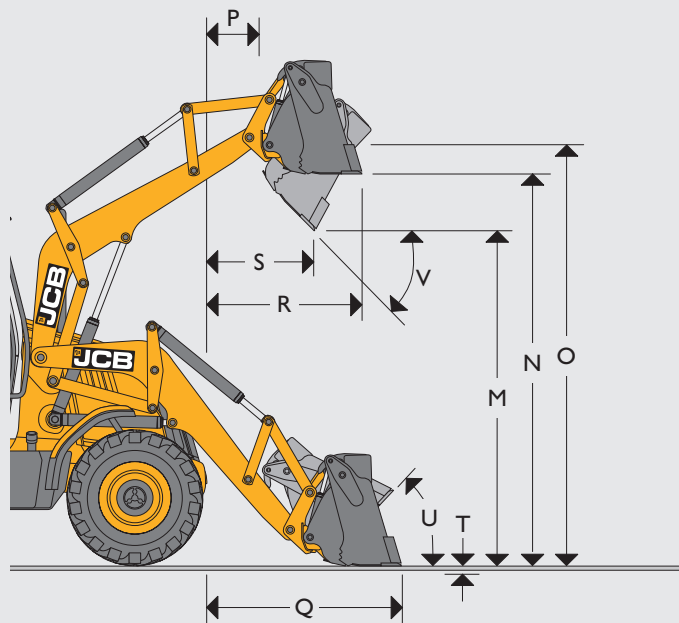

**LOADER ATTACHMENTS**

	Quick Hitch Mounted forks
	m
W Forks - tine length	1.24
X Forks reach at ground level	2.19
Y Forks reach at full height	1.79
Z Forks lift height - max.	3.24
Fork spacing - min.	0.15
Fork spacing - max.	1.28
SWL @ 500mm load centres (kg)	1670
Max. rollback at ground (°)	9.8
Forks - tine width	0.1

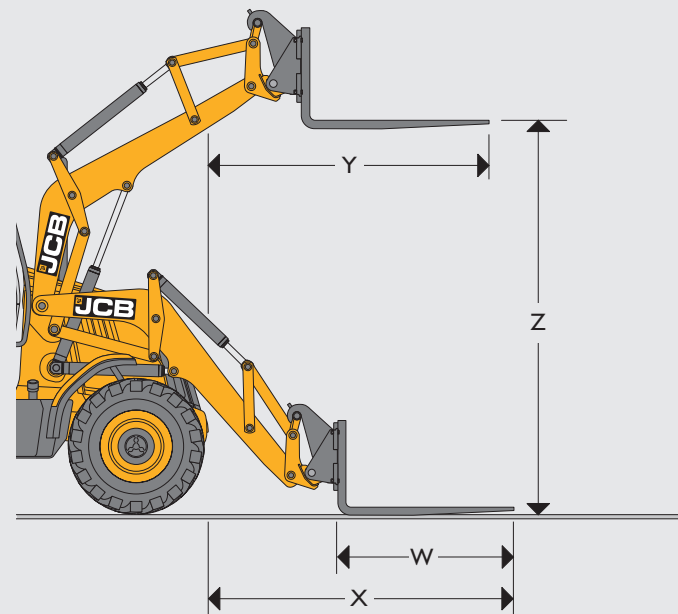

**LOADER PERFORMANCE**

		GP Shovel	6 in 1 Shovel
Loader breakout – shovel	kgf	3758	3618
Loader breakout – arms	kgf	2690	2550
Rated operating capacity*	kg	1526	1386

\*Rated operating as determined according to ISO 14397:2007.



**LOADER ATTACHMENTS – SHOVELS**

All loader shovels are drilled to accept optional auxiliary cutting edge or teeth. Flat top box section provides rigidity and assists in bucket levelling.

	Shovel Capacity SAE	
	Rated m <sup>3</sup>	Struck m <sup>3</sup>
G.P shovel (2000mm)	0.7 (0.92)	0.56 (0.73)
6 in I shovel (2000mm)	0.6 (0.78)	0.49 (0.64)
Narrow G.P shovel (1370mm)	0.6 (0.78)	0.49 (0.64)

**EXCAVATOR ATTACHMENTS – BUCKETS**

JCB Backhoe buckets are designed specifically for use on JCB machines with pin positions to maximize tearout, load retention and straight wall digging characteristics.

Width mm	Capacity SAE	
	Rated m <sup>3</sup>	Struck m <sup>3</sup>
230	0.028	0.022
300	0.03	0.03
350	0.04	0.03
400	0.05	0.04
450	0.06	0.05
600	0.09	0.07
750	0.11	0.09
1200	0.16	-

**EXCAVATOR ATTACHMENTS – BREAKERS**

	Weight kg	Impact energy J
HM166Q	162	252
HM266Q	244	376

**EXCAVATOR PERFORMANCE**

		10ft Fixed	10ft Extending	12ft Fixed	12ft Extending	
Bucket tearout	kgf	3340	3340	3340	3340	
Dipper tearout	kgf	Ext	-	2370	-	2430
		Ret	2770	2870	2740	2870
Lift capacity of bucket pivot at full reach	kg	Ext	-	570	-	-
		Ret	930	690	730	490

**EXCAVATOR DIMENSIONS**

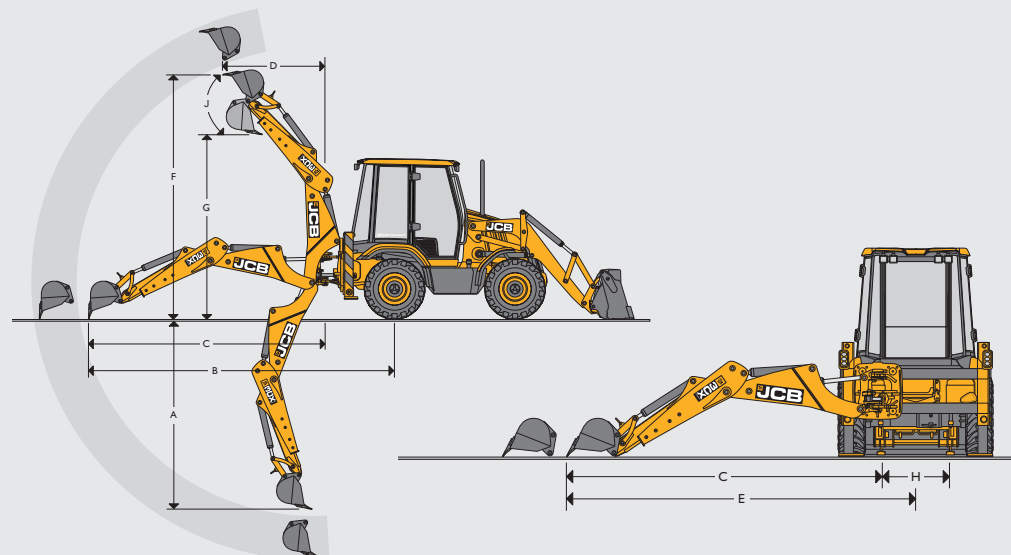

			10ft Standard dipper	10ft Extradig	12ft Standard dipper	12ft Extradig
			m	m	m	m
A	SAE max dig depth	Ext	-	3.72	-	4.33
		Ret	3.07	3.07	3.68	3.68
	SAE 2ft flat bottom	Ext	-	3.70	-	4.26
		Ret	3.04	3.04	3.61	3.61
B	Reach – ground level to rear wheel centre	Ext	-	5.81	-	6.43
		Ret	5.19	5.19	5.82	5.81
C	Reach – ground level to slew centre	Ext	-	4.60	-	5.22
		Ret	3.99	3.99	4.61	4.60
D	Reach – at full height to slew centre	Ext	-	1.90	-	3.16
		Ret	1.41	1.41	2.67	2.67
E	Side reach – to centre line of machine	Ext	-	5.05	-	5.73
		Ret	4.43	4.43	5.15	5.15
F	SAE operating height	Ext	-	4.43	-	4.95
		Ret	4.05	4.05	4.57	4.57
G	Maximum loadover height	Ext	-	3.22	-	3.72
		Ret	2.75	2.75	3.30	3.30
	SAE loadover height	Ext	-	3.18	-	3.68
		Ret	2.72	2.71	3.27	3.26
H	Total kingpost travel	m	1.00	1.00	1.00	1.00
J	Bucket rotation		187°	187°	187°	187°



OUT OF USE

JCB

3CX

JCB

GET NAPP

No smoking









**ONE COMPANY, OVER 300 MACHINES.**

Your nearest JCB dealer

**TOOL CARRIER 3CX COMPACT**

Gross power: 55kW (74hp) Maximum dig depth: 4.33m Weight: 6070kg

JCB Sales Limited, Rokeceter, Staffordshire, United Kingdom ST14 5JP.

Tel: +44 (0)1889 590312 Email: [salesinfo@jcb.com](mailto:salesinfo@jcb.com)

Download the very latest information on this product range at: [www.jcb.com](http://www.jcb.com)

©2015 JCB Sales. All rights reserved. No part of this publication may be reproduced, stored in a retrieval system, or transmitted in any form or by any other means, electronic, mechanical, photocopying or otherwise, without prior permission from JCB Sales. All references in this publication to operating weights, sizes, capacities and other performance measurements are provided for guidance only and may vary dependant upon the exact specification of machine. They should not therefore be relied upon in relation to suitability for a particular application. Guidance and advice should always be sought from your JCB Dealer. JCB reserves the right to change specifications without notice. Illustrations and specifications shown may include optional equipment and accessories. The JCB logo is a registered trademark of J C Bamford Excavators Ltd.

